

e2v

AT84CS001-EB Evaluation Board

.....
User Guide

Table of Contents

Section 1

Introduction	1
1.1 Scope	1
1.2 Description	1

Section 2

Hardware Description	1
2.1 Board Structure	1
2.2 Data and Clock Input Accesses	2
2.3 Digital Output	2
2.4 ASYNCRST	3
2.5 Standalone Delay Cell	3
2.6 DMUX Functions.....	3
2.7 Power Supplies	3

Section 3

Operating Characteristics	1
3.1 Introduction	1
3.2 Operating Procedure	1
3.3 Electrical Characteristics	2

Section 4

Application Information	1
4.1 Introduction	1
4.2 Input Data	1
4.3 Digital Outputs	1
4.4 DMUX Functions	2
4.4.1 ASYNCRST	2
4.4.2 CLKDACTRL	2
4.4.3 DACTRL	3
4.4.4 RS, DRYPE, DAEN, BIST, CLKTYPE, SLEEP, STAGG	4
4.5 Test bench Description	6

Section 5

Package Information	1
5.1 AT84CS001 Pinout	1
5.2 Package Outline	5

Section 6

Ordering Information 1

Section 7

Appendix 1

 7.1 AT84CS001-EB Electrical Schematics 1

 7.2 AT84CS001-EB Board Layers 5

-
- 1.1 Scope**
- The AT84CS001-EB Evaluation Kit is designed to facilitate the evaluation and characterization of the AT84CS001 1:2/4 10-bit 2.2 GHz DMUX up to 2.2 GHz.
- The AT84CS001-EB Evaluation Kit includes
- The 1:2/4 10-bit 2.2 GHz DMUX Evaluation Board
 - Five SMA caps for DAI, DAIN, DAO, DAON and ASYNCRST signals
 - Seven jumpers for the DMUX function settings (RS, BIST, CLKTYPE, DRTYPE, SLEEP, STAGG, DAEN)
- This user guide uses the AT84CS001-EB evaluation Kit as an evaluation and demonstration platform and provides guidelines for its correct use.
-
- 1.2 Description**
- The AT84CS001-EB evaluation board is very straightforward as it only implements the AT84CS001 1:2/4 10-bit 2.2 GHz DMUX device, SMA connectors for the standalone delay cell inputs and outputs and for the reset input accesses and 2.54 mm pitch connectors compatible with high-speed acquisition system probes.
- This evaluation board is fully compatible with e2v high-speed ADC boards (TSEV830500GL, TSEV8388BGL/GLZA2/F/FZA2, TSEV83102G0BGL and AT84AS008GL-EB).
- To achieve optimal performance, the AT84CS001-EB evaluation board was designed in a 4-metal-layer board with RO4003 200 and FR4 HTG dielectric layers. The board implements the following devices:
- The 1:2/4 10-bit 2.2 GHz DMUX Evaluation board
 - Five SMA caps for DAI, DAIN, DAO, DAON and ASYNCRST signals
 - Seven jumpers for the DMUX function settings (RS, BIST, CLKTYPE, DRTYPE, SLEEP, STAGG, DAEN)
 - 2.54 mm pitch connectors for the digital inputs and outputs, compatible with high-speed acquisition system probes
 - Banana jacks for the power supply accesses
 - Potentiometers for the DMUX control functions

The board is comprised of four metal layers for signal traces, ground and power supply layers, and three dielectric layers featuring low insertion loss and enhanced thermal characteristics for operation in the high frequency domain.

The board dimensions are 220 mm x 230 mm.

The board comes fully assembled and tested, with the AT84CS001 installed.

Figure 1-1. Simplified Schematics of the AT84CS001-EB Evaluation Board

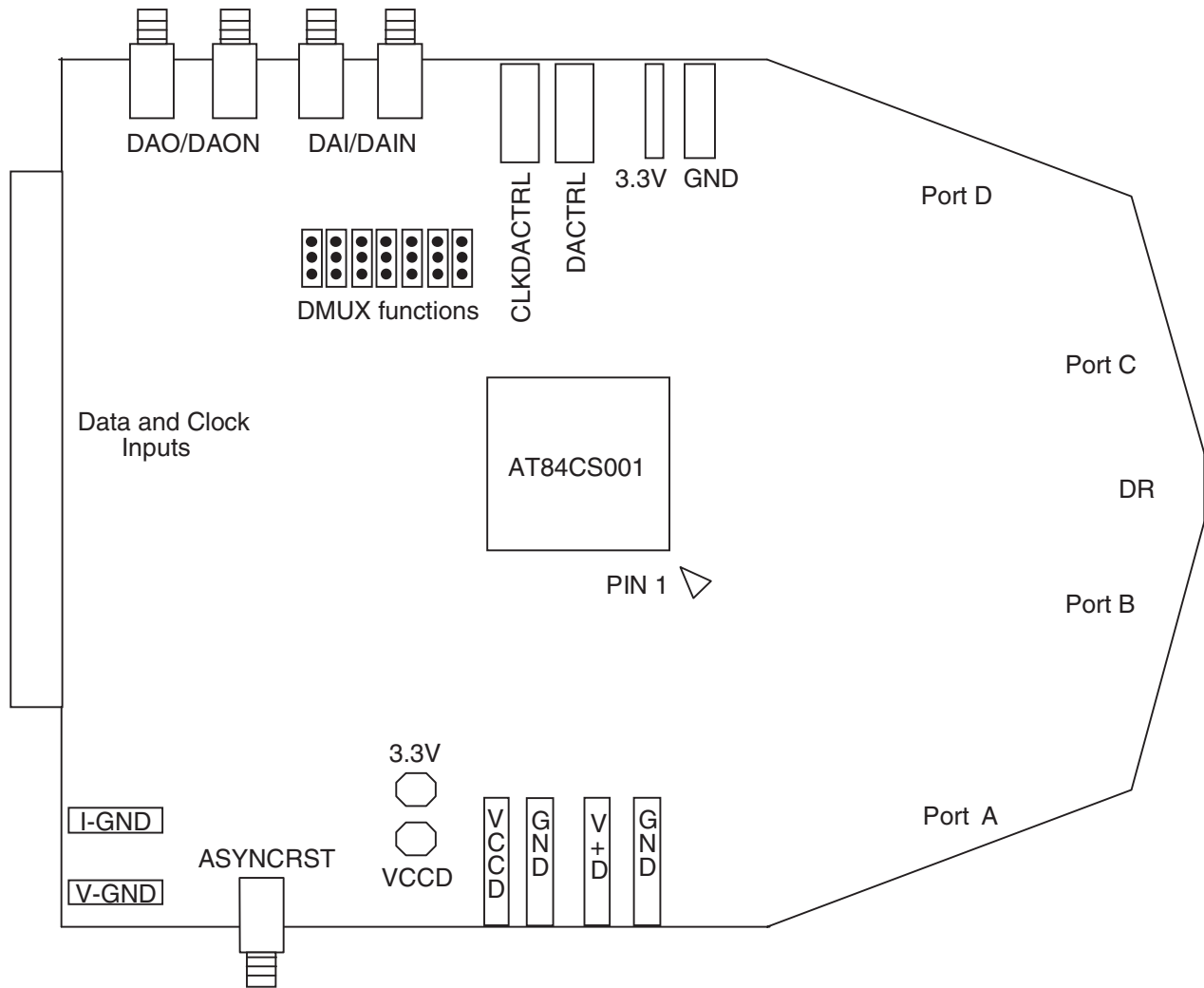

As shown in Figure 1-1, different power supplies are required:

- $V_{CCD} = 3.3V$ digital positive power supply
- $V_{PLUSD} = 2.5V$ digital output power supply
- 3.3V used for the DMUX functions

Hardware Description

2.1 Board Structure

In order to achieve optimum full-speed operation of the AT84CS001 1:2/4 10-bit 2.2 GHz DMUX, a multi-layer board structure was retained for the evaluation board. Four copper layers are used, respectively dedicated to the signal traces, ground planes and power supply planes.

The board is made in RO4003 200 μm and FR4 HTG epoxy dielectric materials.

The following table gives a detailed description of the board's structure.

Table 2-1. Board Structure

Layer	Characteristics
Layer 1 Copper layer	Copper thickness = 40 μm Input and output signals traces = 50 Ω microstrip lines
Layer 2 RO4003 dielectric layer (Hydrocarbon/wovenglass)	Layer thickness = 200 μm Dielectric constant = 3.4 at 10 GHz - 0.044 dB/inch insertion loss at 2.5 GHz - 0.318 dB/inch insertion loss at 18 GHz
Layer 3 Copper layer	Copper thickness = 35 μm Upper ground plane = reference plane
Layer 4 FR4 HTG/dielectric layer	Layer thickness = 1050 μm
Layer 5 Copper layer	Copper thickness = 35 μm Power planes = 3.3V, V_{CCD} and V_{PLUSD}
Layer 6 FR4 HTG/dielectric layer	Layer thickness = 200 μm
Layer 7 Copper layer	Copper thickness = 40 μm Lower ground plane = reference plane

The board is 1.6 mm thick.

The digital data input, output and reset signals are located on the top metal layer.

The function signals are located on the top metal layer and layer 7.

The ground planes are located on layer 3 and 7.

Layer 5 is dedicated to the power supplies (3.3V, V_{CCD} and V_{PLUSD}).

2.2 Data and Clock Input Accesses

Access to the digital data and clock inputs is provided by one female 2.54 mm pitch connector (points) via 50 Ω microstrip lines.

The connector is made of two rows:

- The upper row is dedicated to the data and clock signals
- The lower row is connected to ground
- Each differential signal pair is separated by a connection to ground, as illustrated in Figure 2-1

Figure 2-1. Input Data Connector

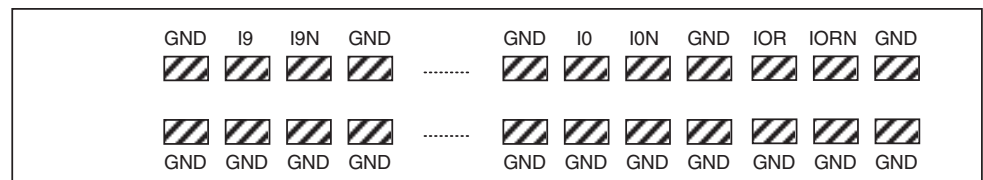

The input lines are matched (in length) within ± 1 mm.

Note: 100 Ω termination is provided on-chip.

2.3 Digital Output

Access to the digital data and clock outputs is provided by four male 2.54 mm pitch connectors (points) via 50 Ω microstrip lines.

The connector is made of two rows:

- The upper row is dedicated to the data and clock signals
- The lower row is connected to ground

Each output port is separated by a connection to ground, as illustrated in Figure 2-2 on page 2-3.

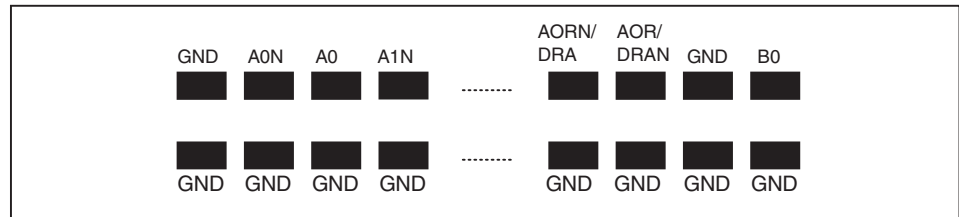
Figure 2-2. Output Data Connector

The digital outputs are compatible with LVDS standard. They are on-board 100 Ω differentially terminated as described in Figure 2-3.

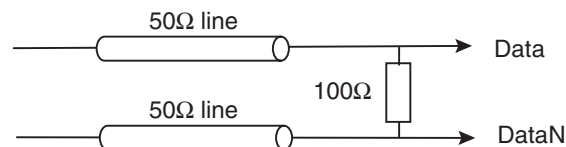
Figure 2-3. Differential Digital Outputs Implementation

The output lines are matched (in length) within ± 5 mm.

-
- 2.4 ASYNCRST** Access to the asynchronous reset is provided by both an SMA connector and a push button.
-
- 2.5 Standalone Delay Cell** Access to the standalone delay cell inputs (DAI/DAIN) and outputs (DAO/DAON) is provided by SMA connectors via 50 Ω microstrip lines.
- Note:** The 100 Ω termination for the DAI/DAIN inputs is provided on-chip, the DAO/DAON outputs are floating (must be terminated by 100 Ω termination).
-
- 2.6 DMUX Functions** Two potentiometers are provided for the DMUX input clock delay control (CLKDACTRL) and the standalone delay cell control (DACTRL).
- Seven jumpers are provided for the RS, BIST, DAEN, SLEEP, STAGG, CLKTYPE and DRTYPE functions (jumper on board = logic 0).
-
- 2.7 Power Supplies** Layer 5 is dedicated to power supply planes (3.3V, V_{CCD} and V_{PLUSD}).
- The supply traces are low impedance and are surrounded by two ground planes (layers 3 and 7).
- V_{CCD} and 3.3V have separated planes but can be short-circuited on the board. The 3.3V supply was separated from V_{CCD} for device power consumption testing purposes.
- Each incoming power supply is bypassed at the banana jack by a 1 μ F Tantalum capacitor in parallel with a 100 nF chip capacitor.

Hardware Description

Each power supply is decoupled as close as possible to the AT84CS001 device by 10 nF in parallel with 100 pF surface mount chip capacitors.

Note: The decoupling capacitors are superimposed with the 100 pF capacitor mounted first.

Operating Characteristics

3.1 Introduction This section describes a typical configuration for operating the evaluation board of the AT84CS001 1:2/4 10-bit 2.2 GHz DMUX.

3.2 Operating Procedure The procedure described below helps you operate the evaluation board for the first time. It described the steps to accomplish a BIST in order to verify whether the board is functional or not. At the end of the procedure, the DMUX is in the following configuration: BIST, 1:4 ratio, CLKTYPE = CLK/2, DRTYPE = DR/2, simultaneous mode, no SLEEP.

Note: Do not switch the power supplies until all power connections on the evaluation board are established.

1. Connect the power supplies and ground accesses through the dedicated banana jacks. $V_{CCD} = 3.3V$, $V_{PLUSD} = 2.5V$ and $3.3V$.
2. Connect the clock input signals (CLK, CLKN). This clock may be single-ended or differential. Use a low-phase noise high frequency generator. You should use an LVDS signal to drive the input clock.
In single-ended mode, CLK must have a common mode voltage equal to 1.25V and CLKN should be connected to a constant value equal to 1.25V. For a differential signal use an LVDS buffer. The clock frequency can range from 1 MHz up to 1.1 GHz (CLK/2 mode) or 2.2 GHz (CLK mode).
3. Remove the jumpers on CLKTYPE, DRTYPE, RS, DAEN, SLEEP and STAGG. The only remaining jumper is on BIST.
4. Connect the high-speed acquisition system probes to the output connectors.

The digital data are differentially terminated on-board (100Ω) but, they can be probed either in differential or in single-ended mode.

All instrumentation and connectors are now connected.

5. Switch on the power supplies (recommended power up sequence: simultaneous or in the following order: $V_{CCD} = 3.3V$, $V_{PLUSD} = 2.5V$ and $3.3V$).

6. Turn on the RF clock generator
7. Perform an asynchronous reset (ASYNCRST push button) on the device.

The AT84CS001-EB evaluation board is now ready for operation in BIST mode.

Note: The BIST comprises a 10-bit sequence available on all four ports of the device (sets the AT84CS001 in 1:4 mode).

The sequence is as follows:

Cycle 0:	Cycle 1:
Port A = 1010101010	Port A = 0101010101
Port B = 1010101010	Port B = 0101010101
Port C = 0101010101	Port C = 1010101010
Port D = 1010101010	Port D = 0101010101

3.3 Electrical Characteristics

Table 3-1. Absolute Maximum Ratings

Parameter	Symbol	Value	Unit
Digital power supply	V_{CCD}	3.6	V
Output power supply	V_{PLUSD}	3.6	V
Data input	I0, I0N...I9, I9N IOR, IORN DAI, DAIN	-0.3 to $V_{CCD} + 0.3$	V
Clock input	VCLK, VCLKN	-0.3 to $V_{CCD} + 0.3$	V
Control inputs	SLEEP, STAGG, ASYNCRST, BIST, RS, DAEN, CLKTYPE, DRTYPE, CLKDACTRL, DACTRL	-0.3 to $V_{CCD} + 0.3$	V
Maximum junction temperature	TJ	125	°C
Storage temperature	Tstg	-65 to 150	°C
Ball temperature	Tballs	300	°C

Note: Absolute maximum ratings are limiting values (referenced to GND = 0V), to be applied individually, while other parameters are within specified operating conditions. Long exposure to maximum rating may affect device reliability. All integrated circuits have to be handled with appropriate care to avoid damages due to ESD. Damage caused by inappropriate handling or storage could range from performance degradation to complete failure.

Table 3-2. Recommended Conditions of Use

Parameter	Symbol	Comments	Recommended	Unit
Positive supply voltage	V_{CCD}		3.3	V
Positive digital supply voltage	V_{PLUSD}		2.5	V
DMUX Control Voltage		CLKDACTRL, DACTRL	$V_{CCD}/3$ to $2 \times V_{CCD}/3$	V
Operating Temperature Range		Industrial "V" grade	$-40^{\circ}\text{C} < T_C; T_J < 110^{\circ}\text{C}$	$^{\circ}\text{C}$

Table 3-3. Electrical Operating Characteristics

Parameter	Symbol	Min	Typ	Max	Unit
Resolution		10-bit with additional 11th bit			Bit
Power Requirements					
Digital power supply voltage	V_{CCD}	3.15	3.3	3.45	V
Output power supply voltage	V_{PLUSD}	2.375	2.5	2.625	V
Digital power supply current - 1:2 mode - 1:4 mode - SLEEP mode - Additional current with SDA enabled - Additional current with BIST enabled	I_{VCCD}		520 580 170 25 40	610 ⁽³⁾ 680 ⁽³⁾ 200 ⁽³⁾	mA
Output power supply current - 1:2 mode - 1:4 mode	I_{VPLUSD}		250 280	350 ⁽³⁾ 380 ⁽³⁾	mA
Power dissipation - 1:2 mode - 1:4 mode - SLEEP mode (1:4) - All active (1:4, BIST & SDA enabled)	P_D		2.4 2.6 1.3 2.8	3.0 ⁽³⁾ 3.3 ⁽³⁾ 3.5 ⁽³⁾	W
LVDS Data/Clock Inputs and Outputs					
Logic Compatibility		LVDS			
Input Common Mode ⁽¹⁾	V_{ICM}	1	1.25	1.6	V
Output Common Mode ⁽²⁾	V_{OCM}	1.125	1.25	1.375	V
Differential input ⁽¹⁾	V_{IDIFF}	100	350	-	mV
Differential output	V_{ODIFF}	250	350	500	mV
Output level "High"	V_{OH}	1.25	1.425	-	V
Output level "Low"	V_{OL}	-	1.075	1.25	V

Operating Characteristics

Table 3-3. Electrical Operating Characteristics (Continued)

Parameter	Symbol	Min	Typ	Max	Unit
Static Inputs (SLEEP, STAGG, BIST, RS, DAEN, CLKTYPE, DRTYPE)					
Control Input Voltages :					
- Logic low	R_{IL}	0		10	Ω
- Logic high	V_{IL} R_{IH} V_{IL}	10k 2.0V		0.5V Infinite	
Static Inputs (CLKDACTRL, DACTRL)					
Control input voltages		$V_{CCD}/3$		$2 \times V_{CCD}/3$	V
Reset input (ASYNCRST)					
Logic compatibility		LVCMOS/CMOS			
Control input voltages:					
- Logic low	V_{IL}	0		1.2	V
- Logic high	V_{IH}	1.5		3.3	
- Common mode	V_{ICM}		1.4		

- Notes:
1. Given for a differential input
 2. Given for a 100 Ω termination across true/false signals
 3. Worst case value obtained with maximum supply voltages over full temperature range

Table 3-4. Switching Performance and Characteristics

Parameter	Symbol	Min	Typ	Max	Unit
Input Clock					
Maximum clock frequency	F_s max	1		1500	MHz
Minimum clock pulse width (high)	TC1	0.3	0.333	500	ns
Minimum clock pulse width (low)	TC2	0.3	0.333	500	ns
Output rise/fall time for data (20% - 80%)	TR/TF			400	ps
Output rise/fall time for Data Ready (20% - 80%)	TR/TF			400	ps
Data output delay	TOD		400		ps
Data Ready output delay	TDR		400		ps
	ITOD - TDRI		0		ps

Table 3-4. Switching Performance and Characteristics (Continued)

Parameter	Symbol	Min	Typ	Max	Unit
Output data to Data Ready propagation delay	TD1	0.3	0.333	500	ps
Data Ready to output data propagation delay	TD2	0.3	0.333	500	ps
Output data pipeline delay: - Synchronized 1:2 mode - Synchronized 1:4 mode - Staggered 1:2 mode - Staggered 1:4 mode	TPD		0.5 1.5 0 / 0.5 0 / 0.5 / 1 / 1.5		Clock cycles

Note: Please refer to the device datasheet entitled “ AT84CS001”, reference 0809.

Application Information

4.1 Introduction For this section, please also refer to the "Main features" section in the "AT84CS001" reference 0809.

4.2 Input Data The input data (I0, I0N...I9, I9N and IOR, IORN) and clock (CLK, CLKN) as well as the DAI, DAIN input data of the standalone delay cell are LVDS compatible (on-chip 100Ω).

Figure 4-1. Input Data and Clock Signals

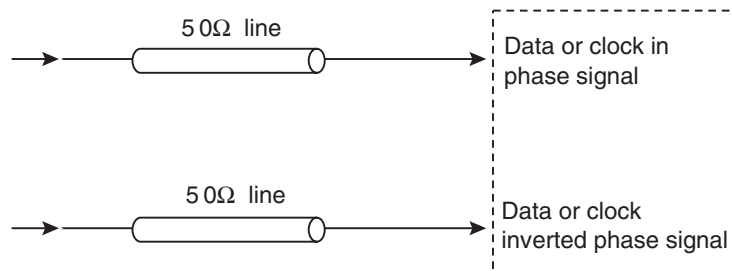

4.3 Digital Outputs The digital outputs (data and Data Ready) are LVDS compatible. The 100Ω differential termination is provided on-board.

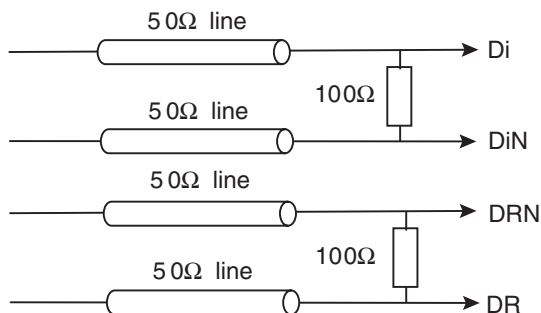
Figure 4-2. Implementation of Differential Digital Outputs

4.4 DMUX Functions

4.4.1 ASYNCRST

The asynchronous reset is mandatory to start the device properly. It must be applied after power up of the device and after any change of DMUX function.

A push button is provided to perform this reset and pull-up and pull-down resistors maintain the ASYNCRST signal in inactive mode.

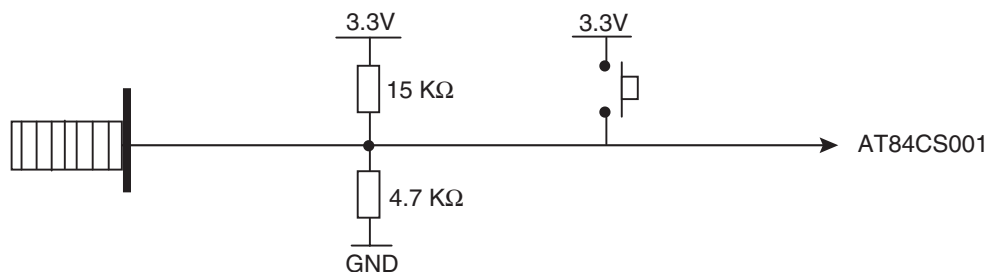
Figure 4-3. ASYNCRST Function

If the DRRB reset is also used, we recommend to apply the asynchronous reset while the DRRB reset is active.

The first data is available at the device output after $TOD + 7.5$ cycles.

4.4.2 CLKDACTRL

A delay cell is provided to allow you to tune the delay between the clock and data at the DMUX input. The delay is controlled via the CLKDACTRL potentiometer.

This cell allows you to delay the internal DMUX clock by approximately 250 ps via the CLKDACTRL potentiometer (varying from $V_{CCD}/3$ to $(2 \times V_{CCD})/3$).

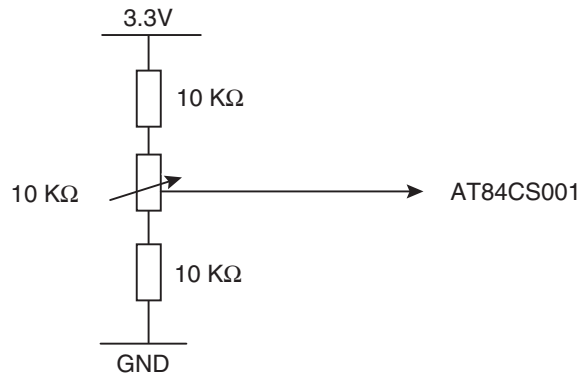
Figure 4-4. CLKDACTRL Function

4.4.3 DACTRL

A standalone delay cell is available (input = DAI/DAIN, output = DAO/DAON, control = DACTRL, enable = DAEN). This cell allows you to delay the incoming signal DAI/DAIN by approximately 250 ps via the DACTRL potentiometer (varying from $V_{CCD}/3$ to $(2 \times V_{CCD})/3$).

4.4.4 RS, DRTYPE, DAEN, BIST, CLKTYPE, SLEEP, STAGG Seven jumpers are provided for the RS, DRTYPE, DAEN, BIST, CLKTYPE, SLEEP and STAGG functions. The following table describes each of these functions.

Table 4-1. Settings and Description of each DMUX Function

Function	Description	Jumper Settings
BIST	Built-In Self Test: - Active: checker-board pattern available at the device's output - Inactive: normal mode	BIST: jumper ON No BIST: jumper OUT
CLKTYPE	Input clock mode: - CLK= data valid on each rising edge of the CLK/CLKN signal - CLK/2 = data valid on both rising and falling edges of the CLK/CLKN signal	CLK: jumper ON CLK/2: jumper OUT
DAEN	Standalone Delay Cell Enable - DAEN active: DAI/DAIN delay can be controlled via DACTRL and output in DAO/DAON - DAEN inactive: the standalone delay cell cannot be used	DAEN active : jumper ON DAEN inactive: jumper OUT
DRTYPE	Output clock mode: - DR/2 = data valid on both rising and falling edges of the DR/DRN signal - DR = data valid on each rising edge of the DR/DRN signal	DR/2: jumper ON DR: jumper OUT
RS	Ratio selection: - 1:2 - 1:4	Jumper ON Jumper OUT
SLEEP	Sleep mode: - Active: the device is in a partial standby mode - Inactive: normal mode	SLEEP: jumper ON Inactive: jumper OUT
STAGG	Simultaneous or staggered output mode: - STAGG active: staggered output data - Inactive: simultaneous output data	STAGG: jumper ON Inactive: jumper OUT

Note: The BIST is comprised of a 10-bit sequence available on all four ports of the device (sets the AT84CS001 in 1:4 mode). The sequence is as follows:

Cycle 0:

Port A = 10101010

Port B = 10101010

Port C = 01010101

Port D = 10101010

Cycle 1:

Port A = 01010101

Port B = 01010101

Port C = 10101010

Port D = 01010101

Figure 4-5. Jumper Positions of DMUX Functions

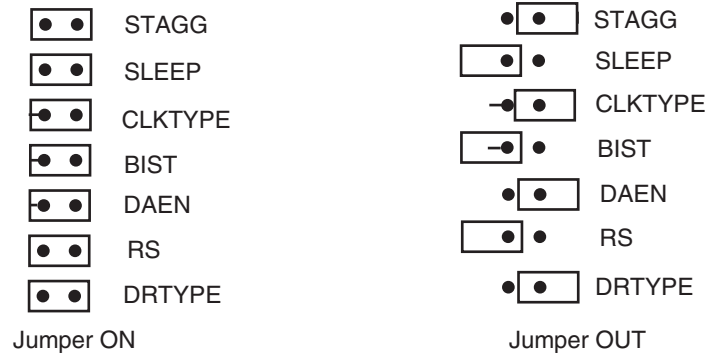

4.5 Test bench Description

Figure 4-6. Test Bench Schematics

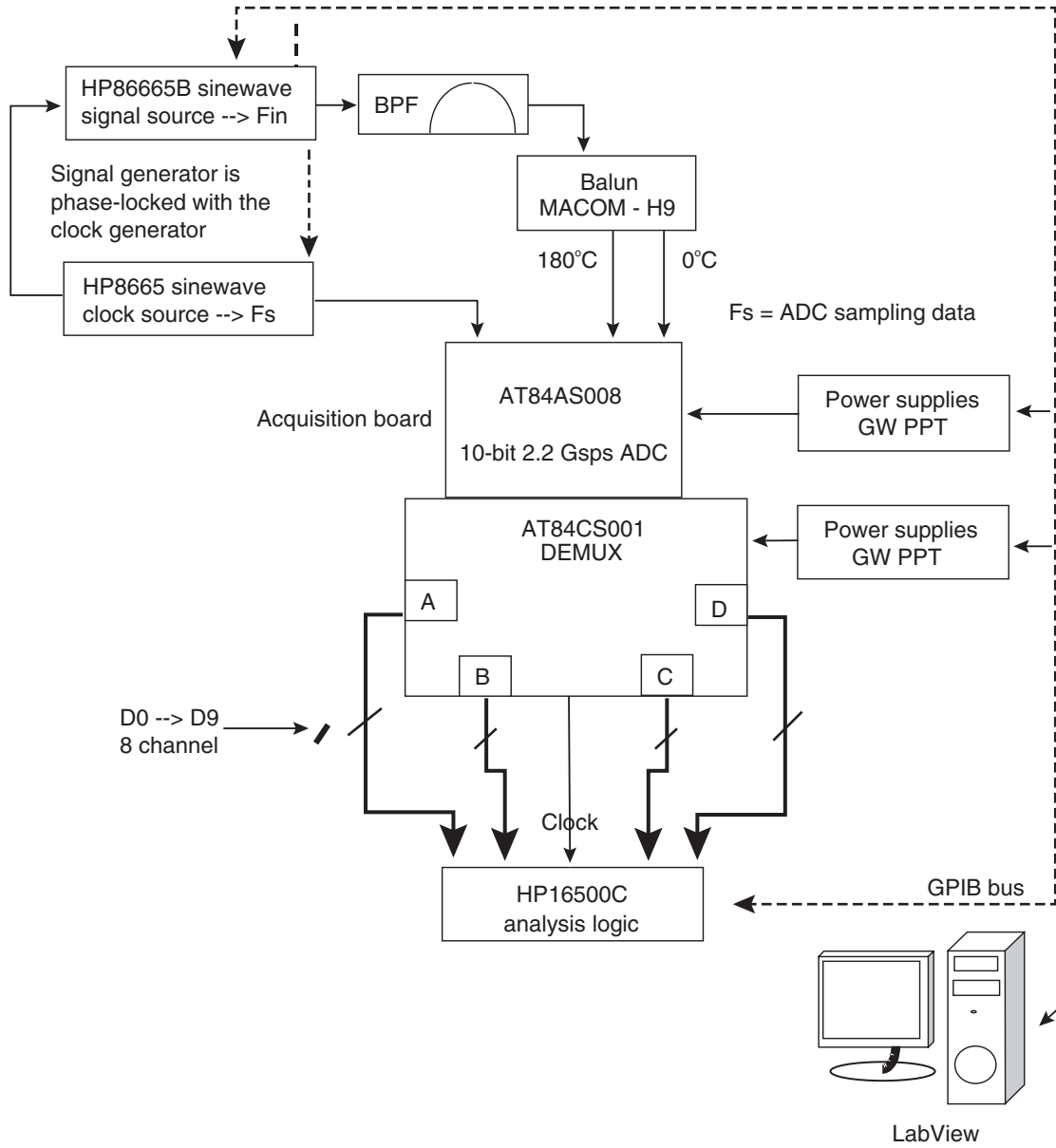

Package Information

5.1 AT84CS001 Pinout (Bottom View)

Figure 5-1. AT84CS001 Pinout

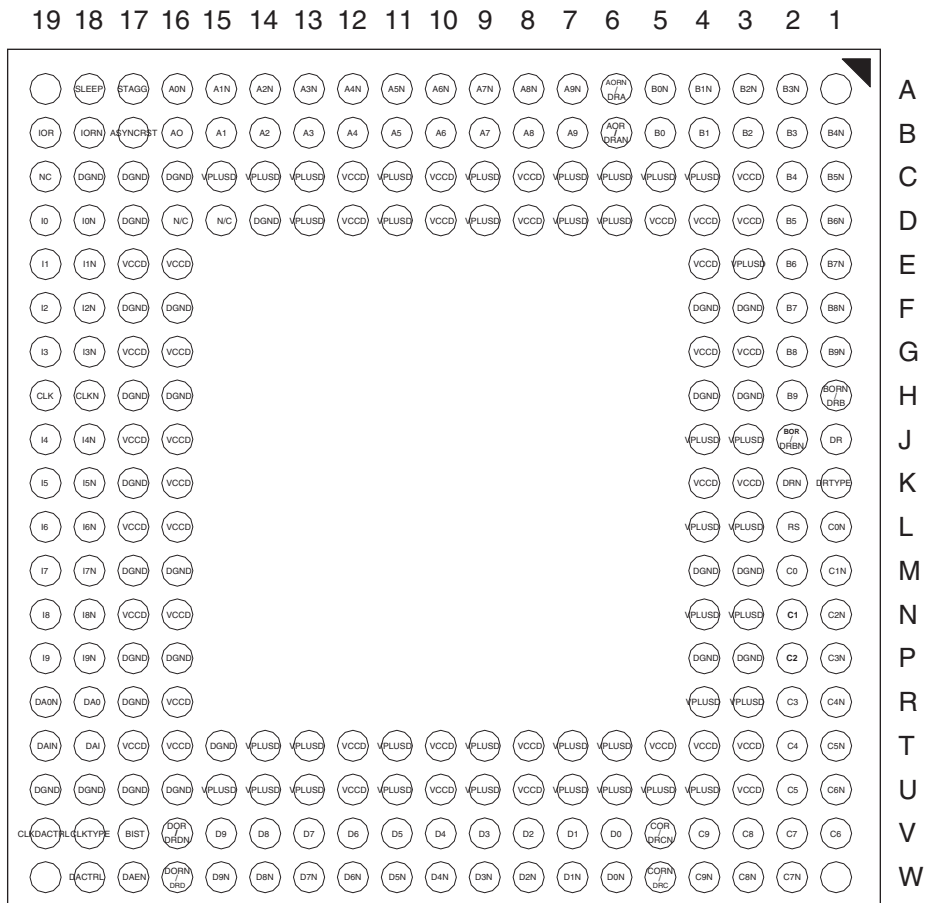

Table 5-1. ASTS8CS001 Pinout Description

Symbol	Pin Number	Function
Power Supply		
V _{CCD}	C12, C10, C8, C3, D12, D10, D8, D5, D4, D3, E17, E16, E4, G17, G16, G4, G3, J17, J16, K16, K4, K3, L17, L16, N17, N16, R16, T17, T16, T12, T10, T8, T5, T4, T3, U12, U10, U8, U3	Digital 3.3V supply
V _{PLUSD}	C15, C14, C13, C11, C9, C7, C6, C5, C4, D13, D11, D9, D7, D6, E3, J4, J3, L4, L3, N4, N3, R4, R3, T14, T13, T11, T9, T7, T6, U15, U14, U13, U11, U9, U7, U6, U5, U4	Output 2.5V supply
DGND	C18, C17, C16, D17, D14, F17, F16, F4, F3, H17, H16, H4, H3, K17, M17, M16, M4, M3, P17, P16, P4, P3, R17, T15, U19, U18, U17, U16	Ground
Digital inputs		
I0, I1, I2, I3, I4, I5, I6, I7, I8, I9	D19, E19, F19, G19, J19, K19, L19, M19, N19, P19	In-phase (+) digital input signal
I0N, I1N, I2N, I3N, I4N, I5N, I6N, I7N, I8N, I9N	D18, E18, F18, G18, J18, K18, L18, M18, N18, P18	Inverted phase (-) digital input signal
IORN	B18	In-phase (+) digital input signal additional bit
IOR	B19	Inverted phase (-) digital input signal for additional bit
DAI	T18	In-phase (+) input signal for standalone delay cell
DAIN	T19	Inverted phase (-) input signal for standalone delay cell
Clock inputs		
CLK	H19	In-phase (+) clock input
CLKN	H18	Inverted phase (-) clock input
Digital inputs		
A0, A1, A2, A3, A4, A5, A6, A7, A8, A9	B16, B15, B14, B13, B12, B11, B10, B9, B8, B7	In-phase (+) digital outputs for port A A0 is the LSB, A9 is the MSB
A0N, A1N, A2N, A3N, A4N, A5N, A6N, A7N, A8N, A9N	A16, A15, A14, A13, A12, A11, A10, A9, A8, A7	Inverted phase (-) digital outputs for port A
AOR/DRAN	B6	In-phase (+) additional bit output for port A or inverted phase (-) output clock for port A in staggered mode
AORN/DRA	A6	Inverted phase (-) additional bit output for port A or In-phase (+) output clock for port A in staggered mode
B0, B1, B2, B3, B4, B5, B6, B7, B8, B9	B5, B4, B3, B2, C2, D2, E2, F2, G2, H2	In-phase (+) digital outputs for port B B0 is the LSB, B9 is the MSB

Table 5-1. ASTS8CSO01 Pinout Description (Continued)

Symbol	Pin Number	Function
B0N, B1N, B2N, B3N, B4N, B5N, B6N, B7N, B8N, B9N	A5, A4, A3, A2, B1, C1, D1, E1, F1, G1	Inverted phase (-) digital outputs for Port B
BOR/DRBN	J2	In-phase (+) additional bit output for port B or inverted phase (-) output clock for port B in staggered mode
BORN/DRB	H1	Inverted phase (-) additional bit output for port B or In-phase (+) output clock for port B in staggered mode
C0, C1, C2, C3, C4, C5, C6, C7, C8, C9	M2, N2, P2, R2, T2, U2, V1, V2, V3, V4	In-phase (+) digital outputs for port C C0 is the LSB, C9 is the MSB
C0N, C1N, C2N, C3N, C4N, C5N, C6N, C7N, C8N, C9N	L1, M1, N1, P1, R1, T1, U1, W2, W3, W4	Inverted phase (-) digital outputs for Port C
COR/DRCN	V5	In-phase (+) additional bit output for port C or inverted phase (-) output clock for port C in staggered mode
CORN/DRC	W5	Inverted phase (-) additional bit output for port C or In-phase (+) output clock for port C in staggered mode
D0, D1, D2, D3, D4, D5, D6, D7, D8, D9	V6, V7, V8, V9, V10, V11, V12, V13, V14, V15	In-phase (+) digital outputs for port D D0 is the LSB, D9 is the MSB
D0N, D1N, D2N, D3N, D4N, D5N, D6N, D7N, D8N, D9N	W6, W7, W8, W9, W10, W11, W12, W13, W14, W15	Inverted phase (-) digital outputs for Port D
DOR/DRDN	V16	In-phase (+) additional bit output for port D or inverted phase (-) output clock for port D in staggered mode
DORN/DRD	W16	Inverted phase (-) additional bit output for port D or In-phase (+) output clock for port D in staggered mode
DR	J1	In-phase (+) Data Ready signal output
DRN	K2	Inverted phase (-) Data Ready signal output
DAO	R18	In-phase (+) output signal for standalone delay cell
DAON	R19	Inverted phase (-) output signal for standalone delay cell
Additional Functions		
ASYNCRST	B17	Asynchronous reset signal
CLKTYPE	V18	Input clock type Selection signal
DRTYPE	K1	Output clock type Selection signal
CLKDACTRL	V19	Clock delay cell control signal
DACTRL	W18	Standalone delay cell control signal
DAEN	W17	Standalone delay cell enable signal
RS	L2	Ratio selection signal
SLEEP	A18	Sleep Mode Selection signal

Table 5-1. ASTS8CS001 Pinout Description (Continued)

Symbol	Pin Number	Function
STAGG	A17	Staggered output mode selection signal
BIST	V17	Built-In Self Test selection signal
NC	C19	Leave floating

5.2 Package Outline

Figure 5-2. Package Outline Schematics

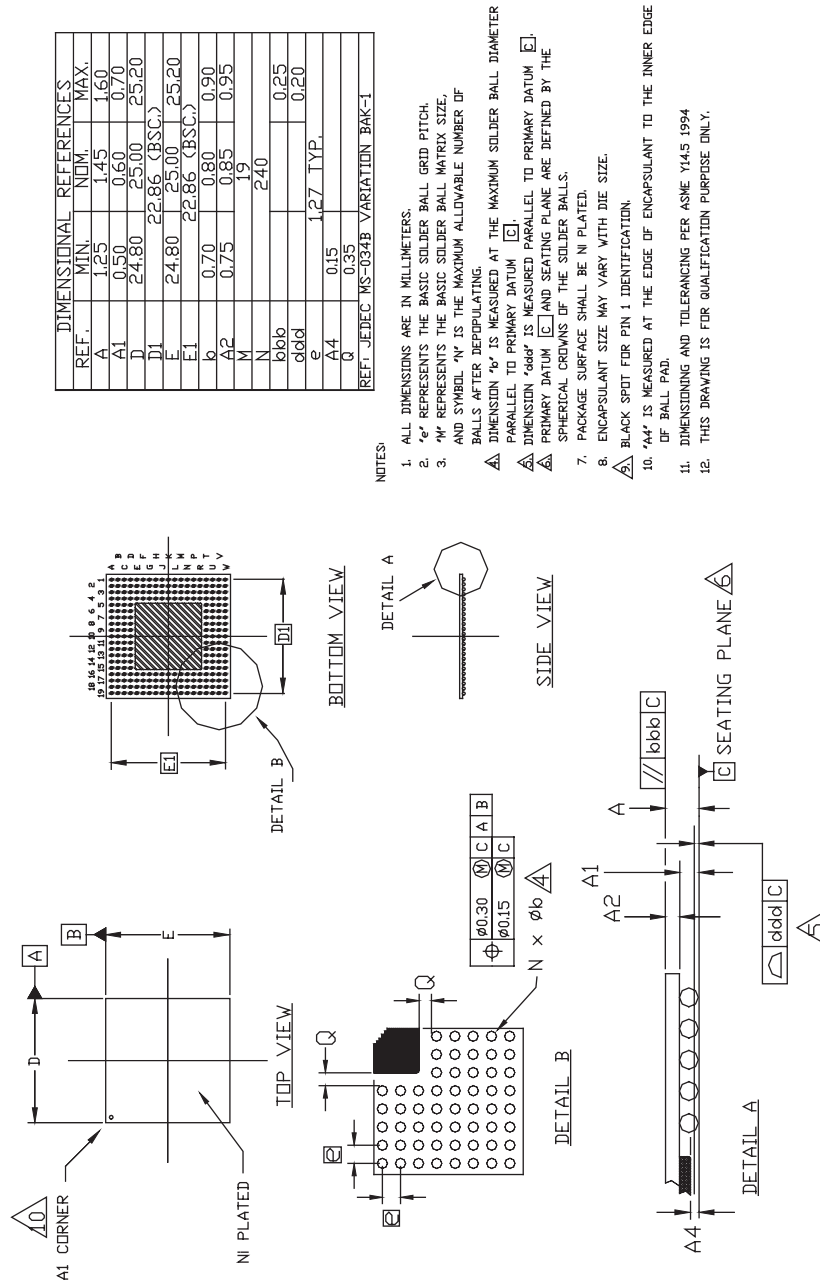

Ordering Information

Table 6-1. Ordering Information

Part Number	Package	Temperature Range	Screening	Comments
AT84XCS001TP	EBGA 240	Ambient	Prototype	Please contact your local sales office
AT84CS001VTP	EBGA 240	Industrial "V" grade -40°C < T _C ; T _J < 110°C	Standard	
AT84CS001VTPY	EBGA240 RoHS	Industrial "V" grade -40°C < T _C ; T _J < 110°C	Standard	
AT84CS001TP-EB	EBGA 240	Ambient	Prototype	Evaluation Kit

7.1 AT84CS001-EB Electrical Schematics

Figure 7-1. Data I/O Electrical Schematic

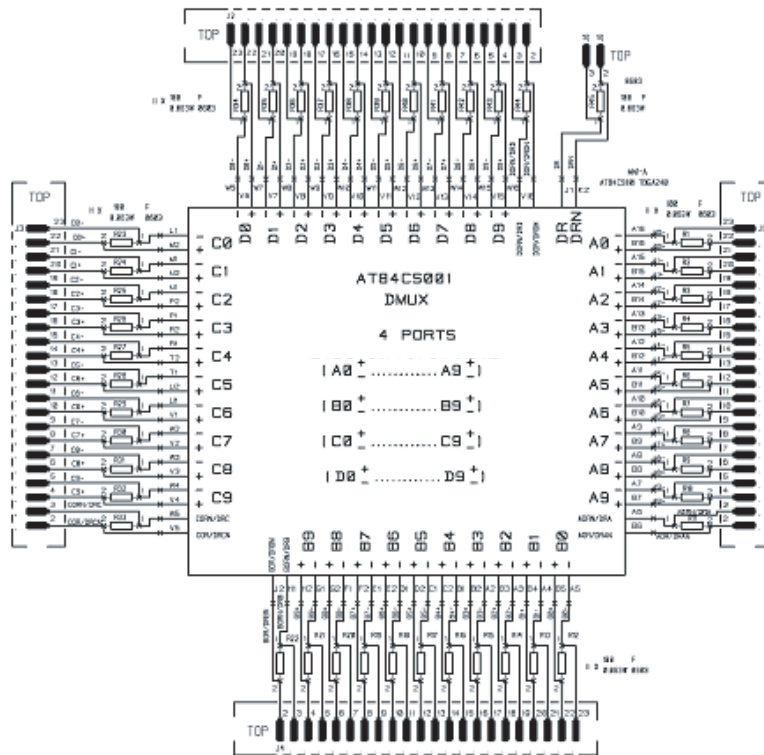

Figure 7-2. Data I/O Electrical Schematic [2]

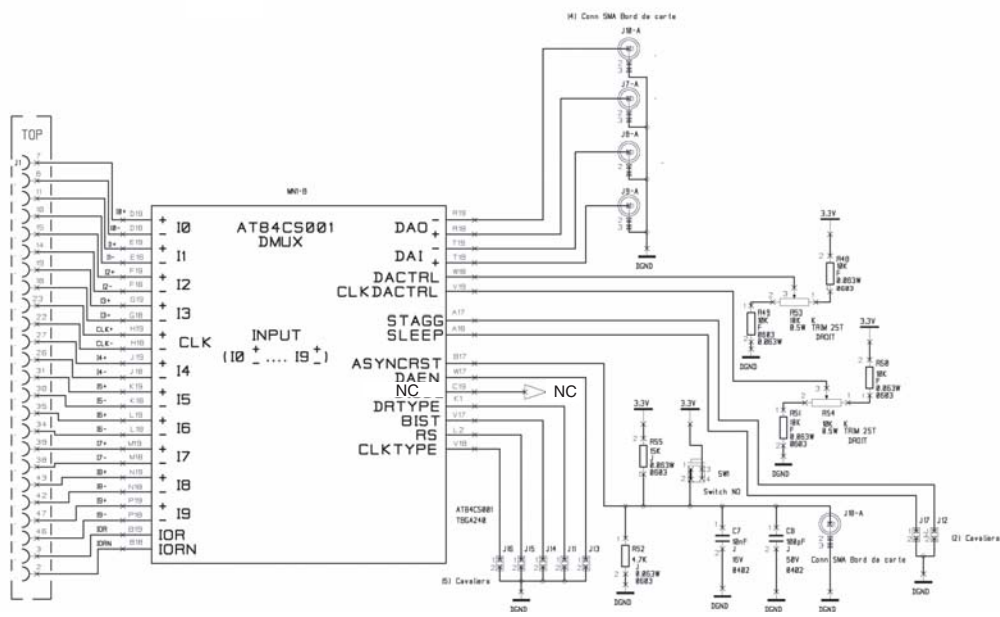

Figure 7-3. Electrical Schematic of Power Supplies [1]

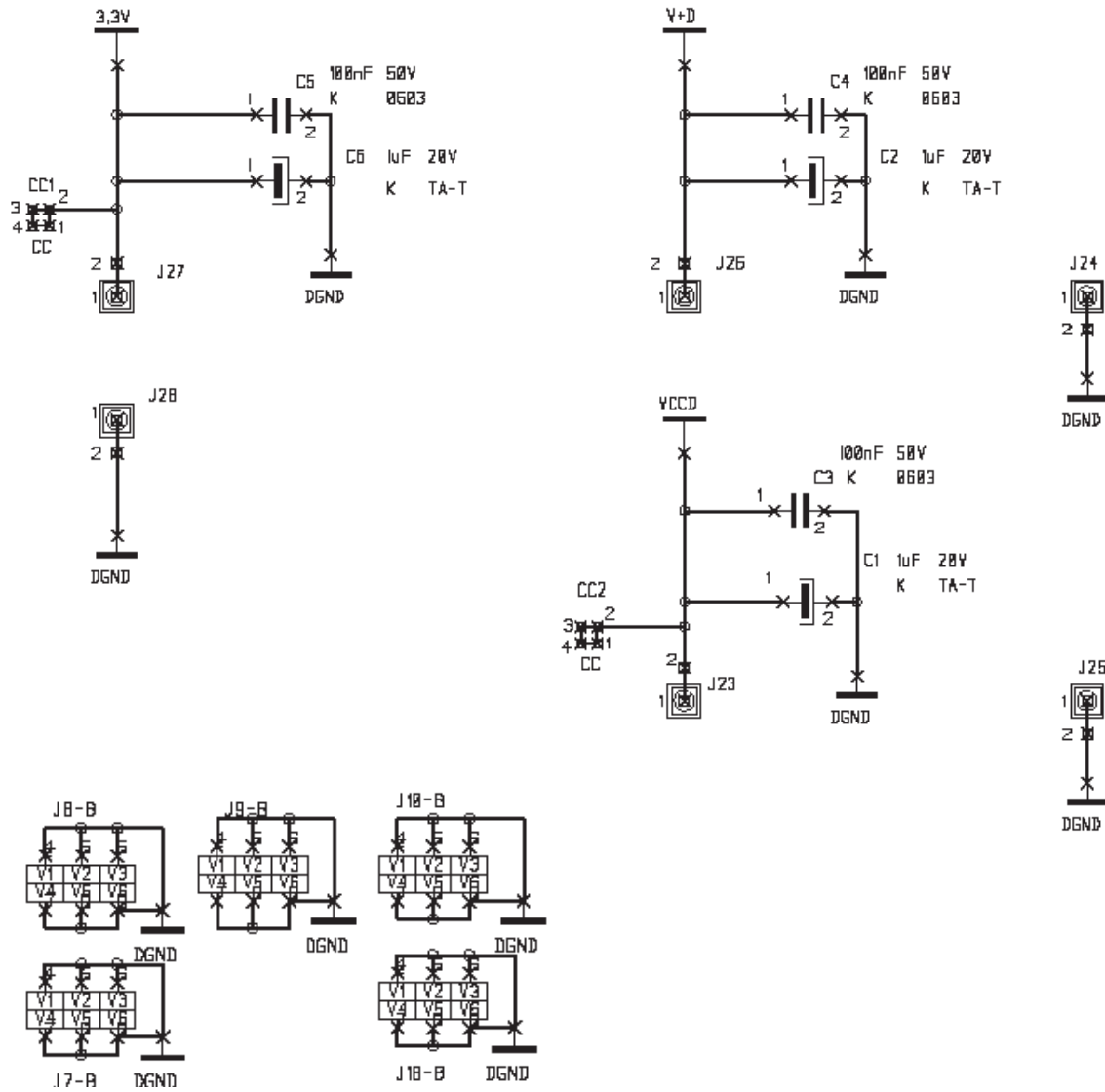

Figure 7-4. Electrical Schematic of Power Supplies [2]

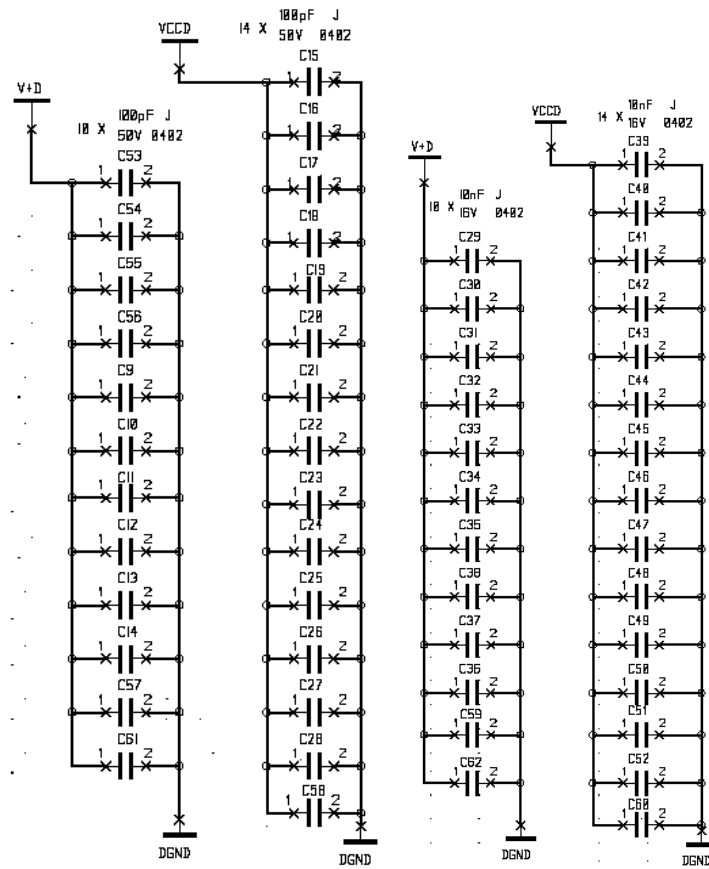

Figure 7-5. Electrical Schematic of Power Supplies [3]

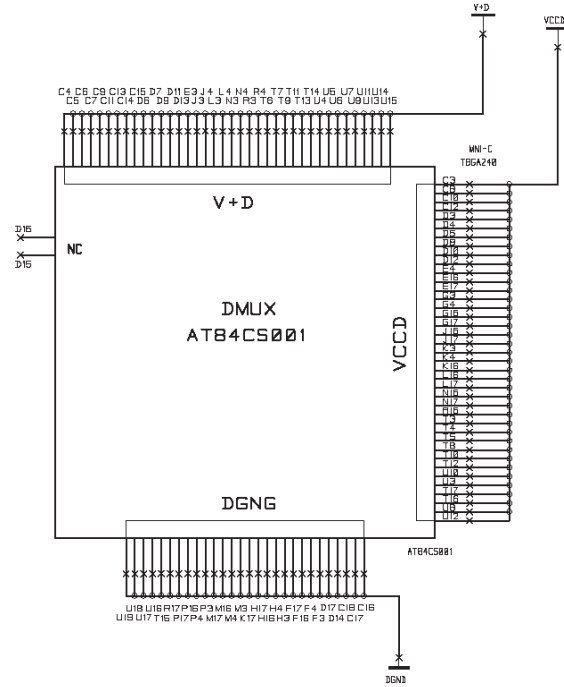

Figure 7-7. Bottom Layer

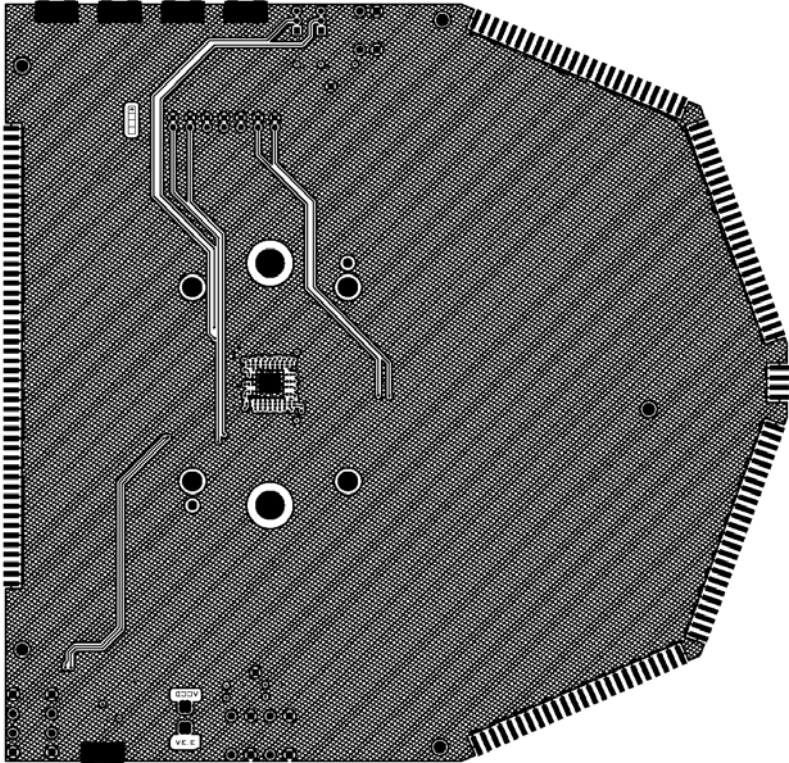
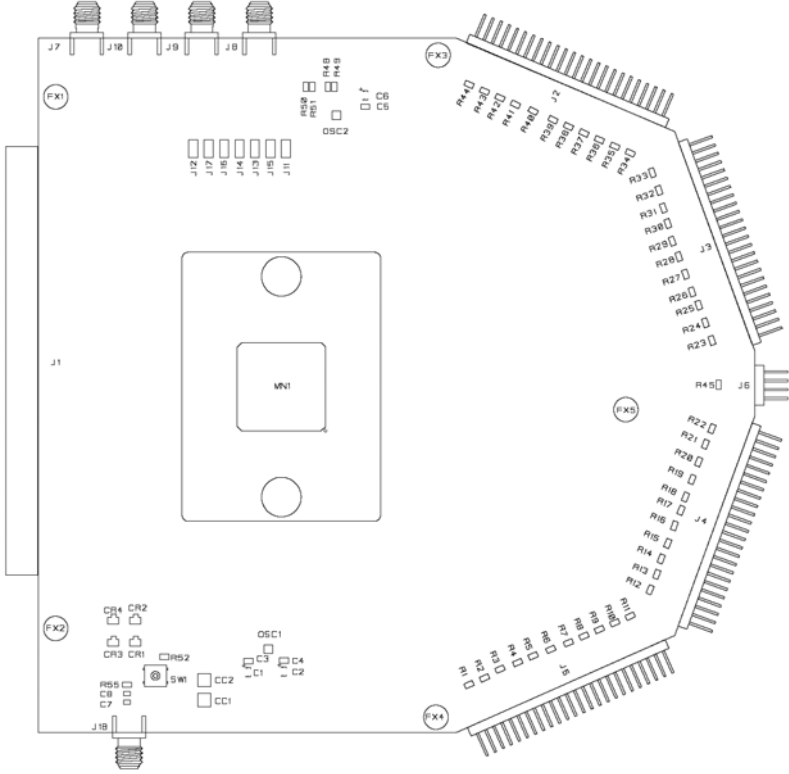

Figure 7-8. Equipped Board (Top)





How to reach us

Home page: www.e2v.com

Sales Office:

Northern Europe

e2v ltd

106 Waterhouse Lane
Chelmsford
Essex CM1 2QU
England
Tel: +44 (0)1245 493493
Fax: +44 (0)1245 492492
E-Mail: enquiries@e2v.com

Southern Europe

e2v sas

16 Burospace
F-91572 Bièvres
Cedex
France
Tel: +33 (0) 16019 5500
Fax: +33 (0) 16019 5529
E-Mail: enquiries-fr@e2v.com

Germany and Austria

e2v gmbh

Industriestraße 29
82194 Gröbenzell
Germany
Tel: +49 (0) 8142 41057-0
Fax: +49 (0) 8142 284547
E-Mail: enquiries-de@e2v.com

Americas

e2v inc.

4 Westchester Plaza
Elmsford
NY 10523-1482
USA
Tel: +1 (914) 592 6050 or
1-800-342-5338,
Fax: +1 (914) 592-5148
E-Mail: enquiries-na@e2v.com

Asia Pacific

e2v

Bank of China Tower
30th floor office 7
1 Garden Rd Central
Hong Kong
Tel: +852 2251 8227/8/9
Fax: +852 2251 8238
E-Mail: enquiries-hk@e2v.com

Product Contact:

e2v

Avenue de Rochepleine
BP 123 - 38521 Saint-Egrève Cedex
France
Tel: +33 (0)4 76 58 30 00
Hotline:
hotline-bdc@e2v.com

Whilst e2v has taken care to ensure the accuracy of the information contained herein it accepts no responsibility for the consequences of any use thereof and also reserves the right to change the specification of goods without notice. e2v accepts no liability beyond that set out in its standard conditions of sale in respect of infringement of third party patents arising from the use of tubes or other devices in accordance with information contained herein.