

# e2v

**AT84AS004-EB Evaluation Board**

.....  
**User Guide**



---

<b>Section 1</b>	
Introduction .....	1-1
1.1 Scope .....	1-1
1.2 Description .....	1-1

---

<b>Section 2</b>	
Hardware Description .....	2-1
2.1 Board Structure .....	2-1
2.2 Analog Inputs/Clock Inputs .....	2-2
2.3 Digital Outputs .....	2-3

---

<b>Section 3</b>	
Operating Characteristics .....	3-1
3.1 Introduction .....	3-1
3.2 Operating Procedure .....	3-1

---

<b>Section 4</b>	
Application Information .....	4-1
4.1 Introduction .....	4-1
4.2 Analog Inputs .....	4-1
4.3 Clock Inputs .....	4-1
4.4 Digital Outputs .....	4-1
4.5 ADC Functions .....	4-2
4.6 DMUX Function .....	4-5
4.7 Diode for Die Junction Temperature Monitoring .....	4-8
4.8 Test Bench Description .....	4-9

---

<b>Section 5</b>	
Package Information .....	5-1
5.1 Thermal Characteristics .....	5-1

---

<b>Section 6</b>	
Ordering Information .....	6-1

---

<b>Section 7</b>	
Appendix .....	7-1
7.1 AT84AS004-EB Electrical Schematics .....	7-1



## Introduction

- 
- 1.1 Scope**
- The AT84AS004-EB Evaluation Kit is designed to facilitate the evaluation and characterization of the AT84AS004 10-bit 2 Gsps ADC with 1:2/4 DMUX up to its 3.3 GHz full power input bandwidth and up to 2 Gsps.
- The AT84AS004-EB Evaluation Kit includes:
- The 10-bit 2 Gsps ADC with 1:2/4 DMUX Evaluation board including the AT84AS004 device soldered and a heat sink screwed on the board
  - 10 SMA caps for CLK, CLKN, VIN, VINN, DAI, DAIN, DAO, DAON, DRRB and AsyncRST signals
  - 12 jumpers for ADC and DMUX function settings (SDAEN, B/GB, PGEB, RS, BIST, CLKTYPE, DRTYPE, SLEEP, STAGG, DAEN)
- The user guide uses the AT84AS004-EB Evaluation Kit as an evaluation and demonstration platform and provides guidelines for its proper use.
- 
- 1.2 Description**
- The AT84AS004-EB evaluation board is very straightforward as it only implements the AT84AS004 10-bit 2 Gsps ADC/DMUX device, SMA connectors for the sampling clock, analog inputs and reset inputs accesses and 2.54 mm pitch connectors compatible with high-speed acquisition system probes.
- To achieve optimal performance, the AT84AS004-EB evaluation board was designed in a 8-metal-layer board with RO4003 200  $\mu\text{m}$  and FR4 HTG epoxy dielectric materials. The board implements the following devices:
- The 10-bit 2 Gsps ADC with 1:2/4 DMUX evaluation board with the AT84AS004 ADC soldered and a heat sink screwed on the board
  - 10 SMA caps for CLK, CLKN, VIN, VINN, DAI, DAIN, DAO, DAON, DRRB and AsyncRST signals
  - 12 jumpers for ADC and DMUX function settings (SDAEN, B/GB, PGEB, RS, BIST, CLKTYPE, DRTYPE, SLEEP, STAGG, DAEN)
  - 2.54 mm pitch connectors for the digital outputs, compatible with high speed acquisition system probes
  - Banana jacks for the power supply accesses and the die junction temperature monitoring functions (2 mm)

- Potentiometers for the ADC and DMUX functions

The board is comprised of 8 metal layers for signal traces, ground and power supply layers, and 7 dielectric layers featuring low insertion loss and enhanced thermal characteristics for operation in the high frequency domain.

The board dimensions are 220 mm × 240 mm.

The board comes fully assembled and tested, with the AT84AS004 installed and with a heat sink.

Figure 1-1. Simplified Schematics of the AT84AS004-EB Evaluation Board

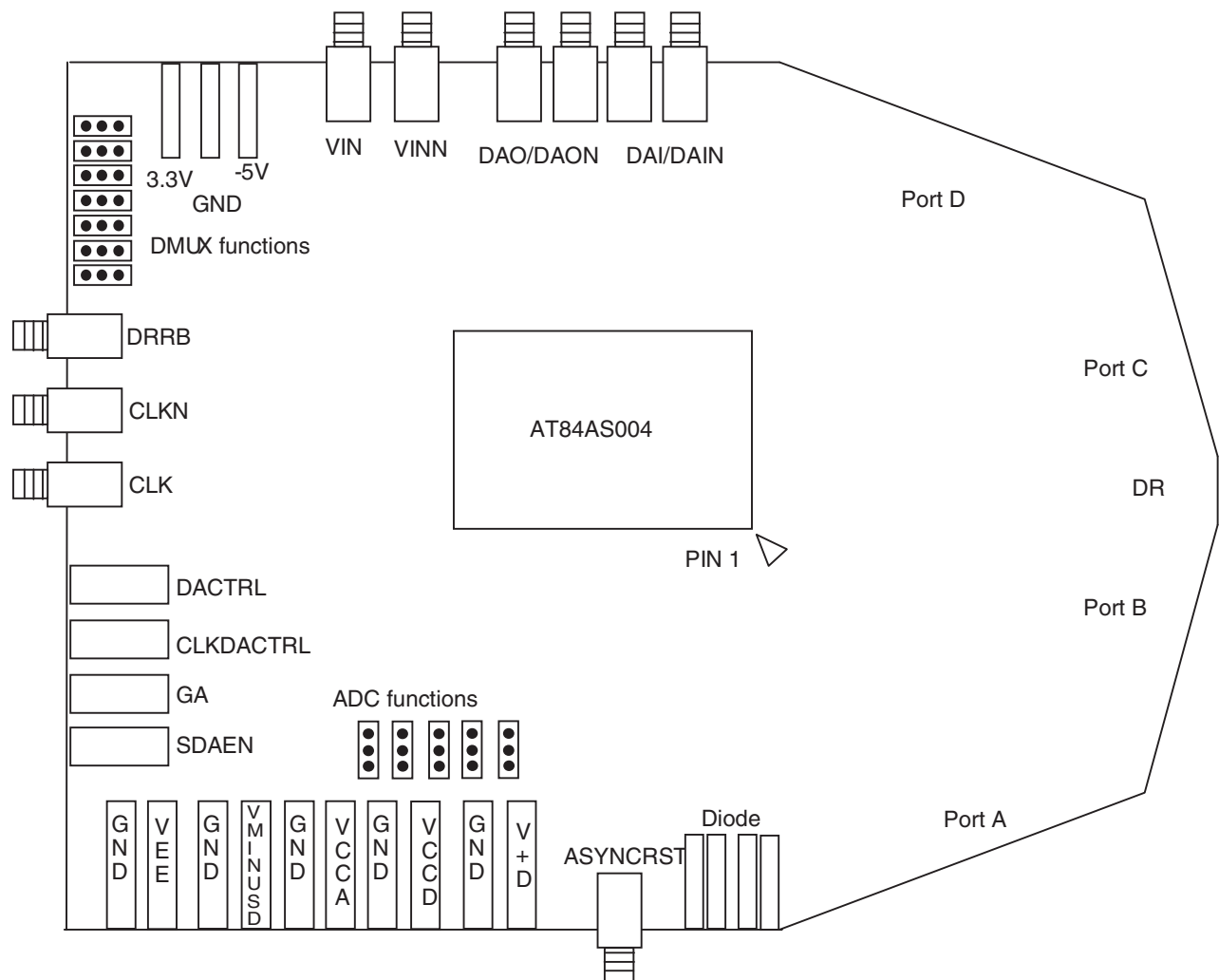

As shown in Figure 1-1, different power supplies are required:

- $V_{EE} = -5V$  analog negative power supply
- $V_{MINUSD} = -2.2V$  digital negative power supply
- $V_{CCA} = 3.3V$  analog positive power supply
- $V_{CCD} = 3.3V$  digital positive power supply
- $V_{PLUSD} = 2.5V$  digital output power supply
- 3.3V and -5V power supplies for the board functions

## Hardware Description

### 2.1 Board Structure

In order to achieve optimum full-speed operation of the AT84AS004 10-bit 2 Gsps ADC with 1:2/4 DMUX, a multi-layer board structure was retained for the evaluation board. Eight copper layers are used, respectively dedicated to the signal traces, ground planes, power supply planes and DC signals traces.

The board is made in RO4003 200  $\mu\text{m}$  and FR4 HTG epoxy dielectric materials.

The following table gives a detailed description of the board's structure.

**Table 2-1.** Board Layer Thickness Profile

Layer	Characteristics
Layer 1 Copper layer	Copper thickness = 40 $\mu\text{m}$ AC signals traces = 50 $\Omega$ microstrip lines DC signals traces (B/GB, GA, ADC Diode, SDA)
Layer 2 RO4003 dielectric layer (Hydrocarbon/wovenglass)	Layer thickness = 200 $\mu\text{m}$ Dielectric constant = 3.4 at 10 GHz -0.044 dB/inch insertion loss at 2.5 GHz -0.318 dB/inch insertion loss at 18 GHz
Layer 3 Copper layer	Copper thickness = 35 $\mu\text{m}$ Upper ground plane = reference plane 50 $\Omega$ microstrip return
Layer 4 FR4 HTG/dielectric layer	Layer thickness = 170 $\mu\text{m}$
Layer 5 Copper layer	Copper thickness = 35 $\mu\text{m}$ Power planes = $V_{CCA}$ and $V_{CCD}$
Layer 6 FR4 HTG/dielectric layer	Layer thickness = 200 $\mu\text{m}$
Layer 7 Copper layer	Copper thickness = 35 $\mu\text{m}$ Power planes = VEE and 3.3V
Layer 8 FR4 HTG/dielectric layer	Layer thickness = 170 $\mu\text{m}$

**Table 2-1.** Board Layer Thickness Profile (Continued)

Layer	Characteristics
Layer 9 Copper layer	Copper thickness = 35 $\mu\text{m}$ Power planes = $V_{\text{PLUSD}}$
Layer 10 FR4 HTG/dielectric layer	Layer thickness = 200 $\mu\text{m}$
Layer 11 Copper layer	Copper thickness = 35 $\mu\text{m}$ Power planes = $V_{\text{MINUSD}}$ , -5V
Layer 12 FR4 HTG/dielectric layer	Layer thickness = 170 $\mu\text{m}$
Layer 13 Copper layer	Copper thickness = 35 $\mu\text{m}$ Ground plane = reference plane (identical to layer 3)
Layer 14 FR4 HTG/dielectric layer	Layer thickness = 200 $\mu\text{m}$
Layer 15 Copper layer	Copper thickness = 40 $\mu\text{m}$ DC signals traces (B/GB, GA, Diode, SDA) Ground plane

The board is 1.6 mm thick.

The clock, analog input, reset and digital data output signals occupy the top metal layer while the ADC and DMUX functions are located on both the top layer and the 15th layer.

The ground planes occupy layer 3, 13 and 15 (partly).

Layer 5, 7, 9 and 11 are dedicated to the power supplies.

## 2.2 Analog Inputs/Clock Inputs

The differential active inputs (clock, analog, DAI/DAIN, DRRB and ASYNCRST) are provided by SMA connectors.

Reference: VITELEC 142-0701-8511

Special care was taken for the routing of the analog input, clock input and DAI/DAIN signals for optimum performance in the high frequency domain:

- 50 $\Omega$  lines matched to  $\pm 0.1$  mm (in length) between VIN and VINN
- 50 mm max line length
- 1.27 mm pitch between the differential traces
- 400  $\mu\text{m}$  line width
- 40  $\mu\text{m}$  thickness
- 850  $\mu\text{m}$  diameter hole in the ground layer below the VIN and VINN ball footprints

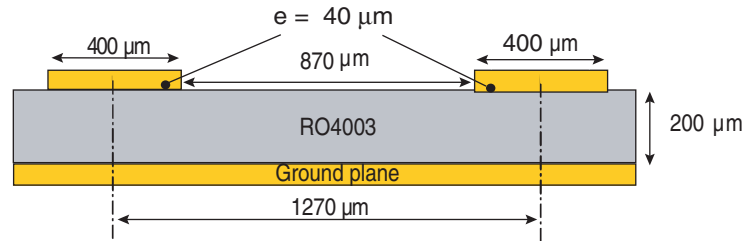

**Figure 2-1.** Board Layout for the Differential Analog, Clock and DAI/DAIN Inputs

**Note:** The analog inputs are reverse terminated with  $50\Omega$  to ground very close to the device (same line length used for both reverse termination).

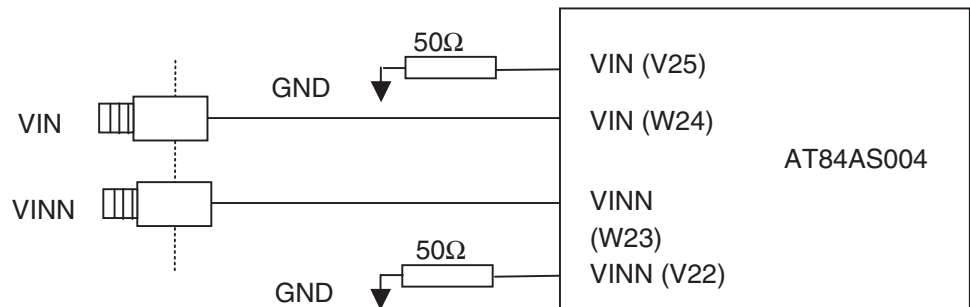
**Figure 2-2.** Differential Analog Inputs Implementation

## 2.3 Digital Outputs

The digital output lines were designed with the following recommendations:

- $50\Omega$  lines matched to  $\pm 0.5$  mm (in length) between signal of the same differential pair
- 80 mm max line length
- $\pm 1$  mm line length difference between signals of two ports
- $\pm 1.5$  mm max line length difference between all signals
- $770\ \mu\text{m}$  pitch between the differential traces
- $370\ \mu\text{m}$  line width
- $40\ \mu\text{m}$  thickness

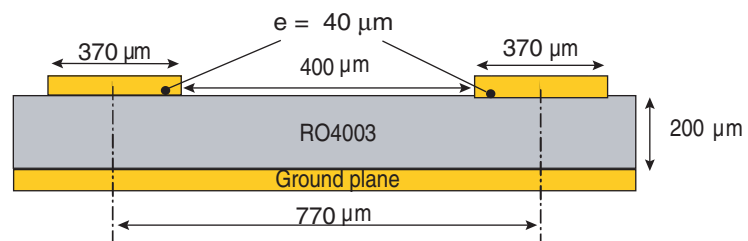
**Figure 2-3.** Board Layout for the Differential Digital Outputs

The digital outputs are compatible with LVDS standard. They are on-board  $100\Omega$  differentially terminated as shown in Figure 2-4 on page 2-4.

**Figure 2-4.** Differential Digital Outputs Implementation

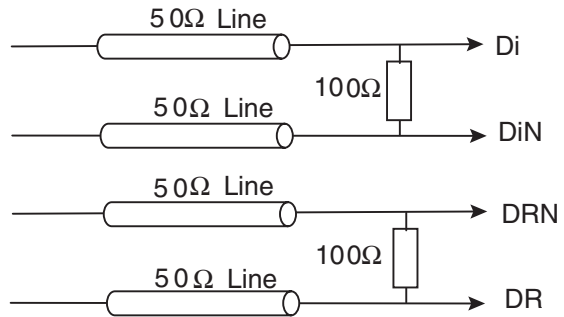

Double row 2.54 mm pitch connectors are used for the digital output data. The upper row is connected to the signal while the lower row is connected to Ground, as illustrated in Figure 2-5

**Figure 2-5.** Differential Digital Clock Outputs 2.54 mm Pitch Connector (Example Port A)

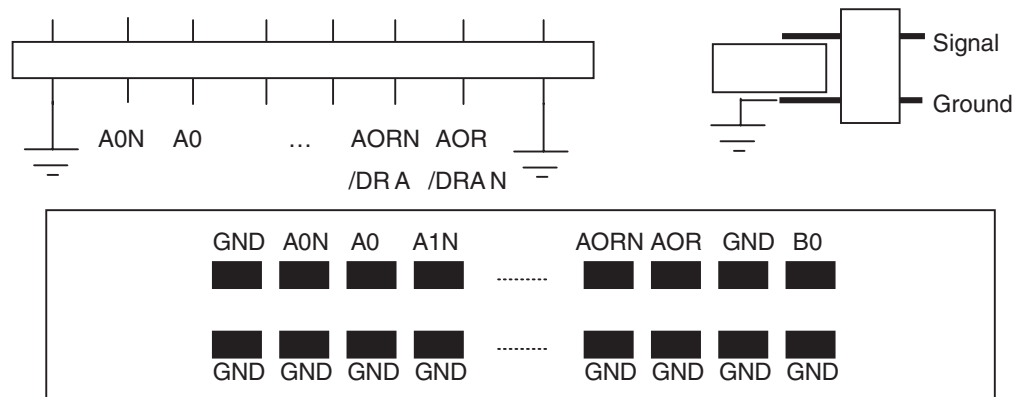

---

## Operating Characteristics

- 
- 3.1 Introduction** This section describes a typical configuration for operating the evaluation board of the AT84AS004 10-bit 2 Gsps ADC with 1:2/4 DMUX.
- The analog input signal and the sampling clock signal can be accessed either in differential or single-ended fashion.
- The single-ended configuration is the most straightforward but it is recommended to work in differential mode (especially for the clock signal) for frequencies above 1 GHz.
- In the case of use in differential mode, the AT84AS004 clock inputs have to be fed with balanced signals (use a balun or Hybrid junction to convert a single signal to a differential signal).
- In the case of use in single-ended mode, the inverted analog input  $V_{INN}$  and clock input CLKN should be terminated properly with  $50\Omega$  to ground ( $50\Omega$  caps can be used to terminate the SMA connectors).
- The RF sources can then be connected directly to the ADC's in-phase analog and clock inputs.
- 
- 3.2 Operating Procedure**
1. Connect the power supplies and ground accesses through the dedicated banana jacks.  $V_{EE} = -5V$ ,  $V_{MINUSD} = -2.2V$ ,  $V_{CCA} = 3.3V$ ,  $V_{CCD} = 3.3V$ ,  $V_{PLUSD} = 2.5V$ ,  $3.3V$  and  $-5V$   
 $V_{CCD} = 3.3V$  and  $3.3V$  and  $V_{EE} = -5V$  and  $-5V$  have separated planes but can be reunited via a short-circuit available on the top metal layer.
  2. Connect the clock input signals. In single-ended mode, terminate the inverted phase signal (CLKN) to a  $50\Omega$  termination to ground ( $50\Omega$  cap). Use a low-phase noise High Frequency generator. The clock input level is typically 0 dBm and should not exceed 4 dBm (into  $50\Omega$ ). The clock frequency can range from 150 MHz up to 2 GHz.
  3. Connect the analog input signal. In single-ended mode,  $V_{INN}$  should be terminated by  $50\Omega$  to ground ( $50\Omega$  cap). Use a low-phase noise High Frequency generator. The analog input full-scale is 500 mV peak-to-peak around 0V ( $\pm 250$  mV). It is recommended to use the ADC with an input signal of -1 dBFS max (to avoid saturation of the ADC). The analog input frequency can range from DC up to 1.8 GHz. At 3.3 GHz, the ADC attenuates the input signal by 3 dB.
  4. Connect the high-speed acquisition system probes to the output connectors.

The digital data are differentially terminated on-board (100Ω) however, they can be probed either in differential or in single-ended mode.

5. Connect the ADC and DMUX function jumpers.

All instrumentation and connectors are now connected.

6. Switch on the power supplies (recommended power up sequence: simultaneous or in the following order:  $V_{EE} = -5V$  and  $-5V$ , then  $V_{MINUSD} = -2.2V$ , and finally  $V_{CCA} = 3.3V$ ,  $V_{CCD} = 3.3V$ ,  $3.3V$  and  $V_{PLUSD} = 2.5V$ ).

7. Switch on the RF clock generator.

8. Switch on the RF signal generator.

9. Perform an asynchronous reset (ASYNCRST push button) on the device.

The AT84AS004-EB evaluation board is now ready for operation

**Table 3-1.** Absolute Maximum Ratings

Parameter	Symbol	Value	Unit
Analog positive supply voltage	$V_{CCA}$	GND to 6	V
Digital positive supply voltage	$V_{CCD}$	GND to 3.6	V
Analog negative supply voltage	$V_{EE}$	GND to -5.5	V
Digital positive supply voltage	$V_{PLUSD}$	GND to 3	V
Digital negative supply voltage	$V_{MINUSD}$	GND to -3	V
Maximum difference between $V_{PLUSD}$ and $V_{MINUSD}$	$V_{PLUSD} - V_{MINUSD}$	5	V
Analog input voltages	$V_{IN}$ or $V_{INN}$	1.5 to 1.5	V
Maximum difference between $V_{IN}$ and $V_{INN}$	$V_{IN}$ or $V_{INN}$	1.5 to 1.5	
Clock input voltage	$V_{CLK}$ or $V_{CLKN}$	-1 to 1	V
Maximum difference between $V_{CLK}$ and $V_{CLKN}$	$V_{CLK} - V_{CLKN}$	-1 to 1	Vpp
Control input voltage	GA, SDAEN	-2 to 0.8	V
Digital input voltage	SDAEN, B/GB, PGEB, DECB	-5 to 0.8	V
ADC reset voltage	DRRB	-5 to 0.8	V
DMUX function input voltage	RS, CLKTYPE, DRTYPE, SLEEP, STAGG, BIST, DAEN	-0.3 to $V_{CCD} + 0.3$	V
DMUX Asynchronous Reset	ASYNCRST	-0.3 to $V_{CCD} + 0.3$	
DMUX input Voltage	DAI, DAIN	-0.3 to $V_{CCD} + 0.3$	V
DMUX control Voltage	CLKDACTRL, DACTRL	-0.3 to $V_{CCD} + 0.3$	V
Maximum input voltage on DIODE	DIODE ADC	700	mV
Maximum input current on DIODE	DIODE ADC	1	mA
Junction temperature	$T_J$	135	°C

- Note:
1. Absolute maximum ratings are short term limiting values (referenced to GND = 0 V), to be applied individually, while other parameters are within specified operating conditions. Long exposure to maximum ratings may affect device reliability.
  2. All integrated circuits have to be handled with appropriate care to avoid damage due to ESD. Damage caused by inappropriate handling or storage could range from performance degradation to complete failure

**Table 3-2.** Operating Characteristics Ambient Temperature ( $V_{CCA} = V_{CCD} = 3.3V$ ,  $V_{EE} = -5V$ ,  $V_{MINUSD} = -2.2V$ ;  $V_{PLUSD} = 2.5V$ ;  $V_{INN} - V_{INN} = 1$  dBFS,  $P_{CLK} = 0$  dBm Differential)

Parameter	Symbol	Min	Typ	Max	Unit
<b>Resolution</b>			10		Bit
<b>Power Requirements</b>					
Positive supply voltage - Analog - Digital - Output $V_{CCD}$	$V_{CCA}$ $V_{CCD}$ $V_{PLUSD}$	3.15 3.15 2.4	3.3 3.3 2.5	3.45 3.45 2.6	V V V
Positive supply current - Analog $V_{CCA}$ - Digital $V_{CCD}$ 1:2 DMUX - Digital $V_{CCD}$ 1:4 DMUX - Output $V_{CCD}$	$I_{VCCA}$ $I_{VCCD}$ $I_{VCCD}$ $I_{VPLUSD}$		75 535 565 450	80 590 620 470	mA mA mA mA
Negative supply voltage	$V_{EE}$	-5.25	-5	-4.75	V
Negative supply current	$I_{VEE}$		590	620	mA
Negative supply voltage	$V_{MINUSD}$	-2.3	-2.2	-2.1	V
Negative supply current	$V_{MINUSD}$		190	200	mA
Power Dissipation (1:2 DMUX)	PD		6.5	6.9	W
<b>Analog Inputs</b>					
Full-scale input voltage range (differential mode) (0V common mode voltage)	$V_{IN}$ $V_{INN}$	-125 -125		125 125	mV mV
Full-scale input voltage range (single-ended input option) (0V common mode voltage)	$V_{IN}$ , $V_{INN}$	-250	0	250	mV
Analog input power level (50 $\Omega$ single-ended)	$P_{IN}$		-2		dBm
Analog input capacitance (die)	$C_{IN}$		0.3		pF
Input leakage current	$I_{IN}$		10		$\mu$ A
Input resistance - Single-ended - Differential	$R_{IN}$ $R_{IN}$	49 98	50 100	51 102	$\Omega$ $\Omega$
<b>Clock Inputs</b>					
Logic common mode compatibility for clock inputs			Differential ECL to LVDS (AC coupling)		

## Operating Characteristics

**Table 3-2.** Operating Characteristics Ambient Temperature ( $V_{CCA} = V_{CCD} = 3.3V$ ,  $V_{EE} = -5V$ ,  $V_{MINUSD} = -2.2V$ ;  $V_{PLUSD} = 2.5V$ ;  $V_{INN} - V_{INN} = 1$  dBFS,  $P_{CLK} = 0$  dBm Differential (Continued)

Parameter	Symbol	Min	Typ	Max	Unit
Clock input common voltage range ( $V_{CLK}$ or $V_{CLKN}$ ) (DC coupled clock input)	$V_{CM}$	-1.2	0	0.3	V
Clock input power level (low-phase noise sinewave input) 50 $\Omega$ single-ended or 100 $\Omega$ differential	$P_{CLK}$	-4	0	4	dBm
Clock input swing (single ended; with CLKN = 50 $\Omega$ to GND)	$V_{CLK}$	$\pm 200$	$\pm 320$	$\pm 500$	mV
Clock input swing (differential voltage) on each clock input	$V_{CLK}, V_{CLKN}$	$\pm 141$	$\pm 226$	$\pm 354$	mV
Clock input capacitance (die)	$C_{LK}$		0.3		pF
Clock input resistance - Single-ended - Differential ended	$R_{CLK}$ $R_{CLK}$	45 90	50 100	55 110	$\Omega$ $\Omega$
<b>Digital Data Outputs</b>					
Logic compatibility			LVDS		
50 $\Omega$ transmission lines, 100 $\Omega$ (2 $\times$ 50 $\Omega$ differential termination)	$V_{OL}$	–	1.075	1.25	V
- Logic low	$V_{OH}$	1.25	1.425	–	V
- Logic high	$V_{ODIFF}$	250	350	450	mV
- Differential output	$V_{OCM}$	1.125	1.25	1.375	V
- Common mode					
<b>Control Function Inputs</b>					
DRRB and ASYNCRST - Logic low - Logic high	$V_{IL}$ $V_{IH}$	0 1.45		1.35 3.3	V V
RS, DRTYPE, SLEEP, STAGG, BIST, DAEN - Logic low - Logic high	$R_{IL}$ $R_{IH}$	0 10 K		10 Infinite	$\Omega$ $\Omega$
SDAEN, PGEB, B/GB - Logic low - Logic high			$V_{EE}$ 0	-3 0	V V
DAI, DAIN Differential Input common mode	$V_{IDIFF}$ $V_{ICM}$	1 100	1.25 350	1.6 –	V mV
GA, SDA		-0.5		0.5	V
CLKDACTRL, DACTRL		$1/3 \times V_{CCD}$		$2/3 \times V_{CCD}$	V

# Application Information

**4.1 Introduction** For this section, refer also to the product “Main features” section of the AT84AS004 datasheet.

**4.2 Analog Inputs** The analog inputs can be entered in differential or in single-ended mode but a differential mode is recommended using a balun or hybrid junction.

In single-ended mode, the unused input signal SMA connector should be terminated with a  $50\Omega$  cap to provide proper termination of the differential pair.

It is recommended that a filter be used to optimize the dynamic performance and the spectral response of the ADC.

**4.3 Clock Inputs** The clock inputs can be entered in differential or in single-ended mode without any high speed performance degradation for a clock frequency up to 1 GHz. At higher rates, it is recommended to drive the clock inputs differentially using a balun or hybrid junction.

In single-ended mode, the unused clock input signal SMA connector should be terminated with a  $50\Omega$  cap to provide proper termination of the differential pair.

The clock can be supplied with a sinewave signal centered on 0V common mode.

**4.4 Digital Outputs** The digital outputs (data and Data Ready) are LVDS compatible.  $100\Omega$  differential termination is provided on-board.

**Figure 4-1.** Differential Digital Outputs Implementation

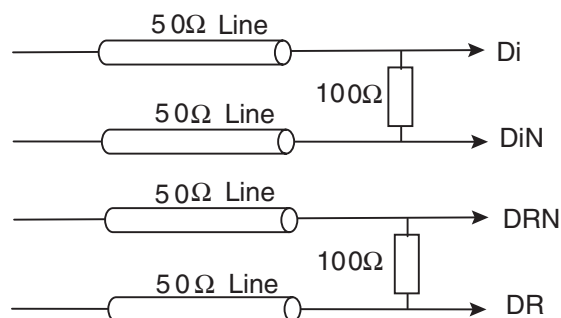

## 4.5 ADC Functions

**4.5.1 Data Ready Reset** The Data Ready reset signal is accessed via an SMA connector.

DRRB is CMOS/LVCMOS compatible:

- $V_{IL} = 0$  (typical)
- $V_{IH} = V_{CCA}$  (typical)

This signal acts as an internal reset of the device. It is not mandatory for proper operation of the device. It is only used to determine exactly the first data to be sampled.

When applied, the clock outputs are reset. The reset pulse should last at least 1 ns.

An asynchronous reset (ASYNCRST push button) should be applied while DRRB is active (low) in order to reset properly the whole device.

In most cases (single channel application, no need to know which data will be the first one to be sampled), this reset can be left unused.

**4.5.2 Binary or Gray Output Coding**

One jumper is used to set the ADC output coding mode in either Binary or Gray:

- Binary coding: connect the jumper to ground
- Gray coding: connect the jumper to the upper position

**Figure 4-2.** Binary or Gray Coding Jumper Position

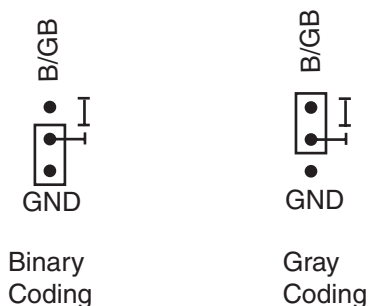

**4.5.3 Gain Adjust**

The ADC gain can be adjusted by the means of the GA potentiometer (varying from -0.5V to 0.5V around 0V nominal value). A GA jumper is available to allow or disable this function.

When connected to ground, the Gain adjustment is disabled. In the other position, the user can tune the ADC gain by varying the GA potentiometer.

The GA potentiometer allows you to tune the Gain from approximately 0.85 to 1.15.



Figure 4-3. ADC Gain Adjust Jumper Settings

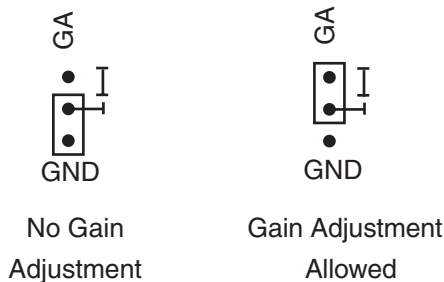
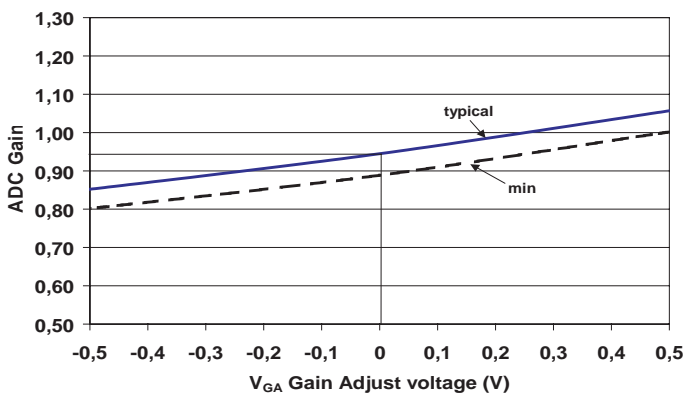

Figure 4-4. The ADC Gain Adjust Function is given in Figure 4.4



4.5.4 Sampling Delay Adjust

The SDA function (Sampling delay adjust) allows to fine tune the sampling ADC aperture delay TA around its nominal value (160 ps). This functionality is enabled thanks to the SDAEN signal, which is inactive when its associated jumper is connected to GND, or active in the other position

Figure 4-5. DC SDAEN Jumper Settings



The variation of the delay around its nominal value as function of SDA voltage is shown in Figure 4-6 on page 4-4.

The typical tuning range is ±120 ps for an applied control voltage varying between -0.5 V to 0.5 V on SDA potentiometer. The variation of the delay in function of the temperature is negligible.

Figure 4-6. SDA Transfer Functions

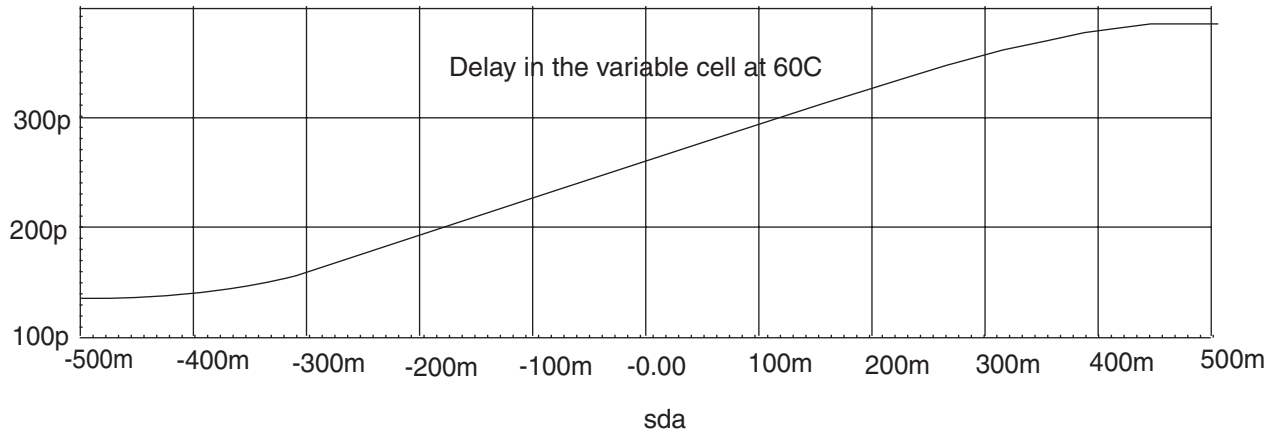

4.5.5 Pattern Generator

The AT84AS004 is able to generate by itself (no need of analog input signal) a series of patterns made of 10-bit transitioning from 0 to 1 or 1 to 0 every cycle.

At the AT84AS004 output, all bits of each port are all 1 or all 0 and do not transition every cycle (all bits of all ports remain the same: that is, if port A = 1010101010, then at next cycle, port A = 1010101010). Ports A and C output the same data, ports B and D output the inverted data compared to ports A and D.

This pattern generator can be used to test the ADC part of the device (a BIST is available for the testing of the DMUX part of the device).

One jumper is used to set the ADC in this Test mode:

- Pattern Generator inactive: connect the jumper to ground
- Pattern Generator active: connect the jumper to the upper position (see Figure 4-3 on page 4-3)

Figure 4-7. Pattern Generator Enable Jumper Position

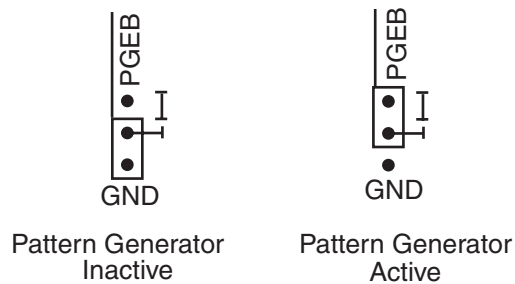

## 4.6 DMUX Function

### 4.6.1 ASYNCRST

The asynchronous reset is mandatory to start the device properly. It must be applied after power up of the device.

A push button is provided to perform this reset and pull-up and pull-down resistors allow to keep the ASYNCRST signal inactive.

**Figure 4-8.** Reset Function

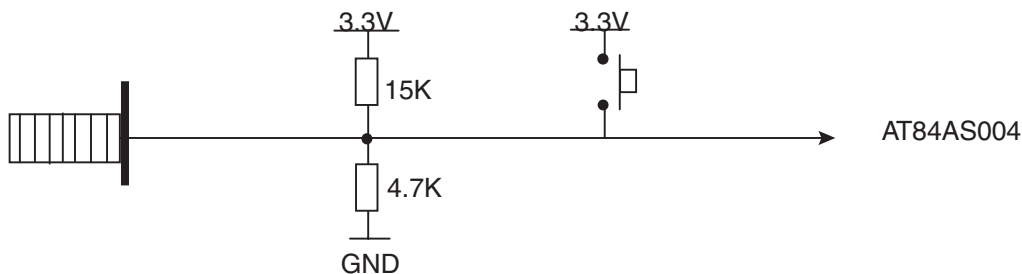

If the DRRB reset is also used, it is recommended to apply the asynchronous reset while the DRRB reset is active.

The first data is available at the device output after  $TOD + 7.5$  cycles.

### 4.6.2 CLKDACTRL

A delay cell is provided to allow you to tune the delay between the clock and data at the DMUX input. The delay is controlled via the CLKDACTRL potentiometer.

This cell allows you to delay by  $\pm 250$  ps (around 250 ps) the internal DMUX clock via the CLKDACTRL potentiometer (varying from  $V_{CCD}/3$  to  $(2 \times V_{CCD})/3$ ).

**Figure 4-9.** CLKDACTRL Function

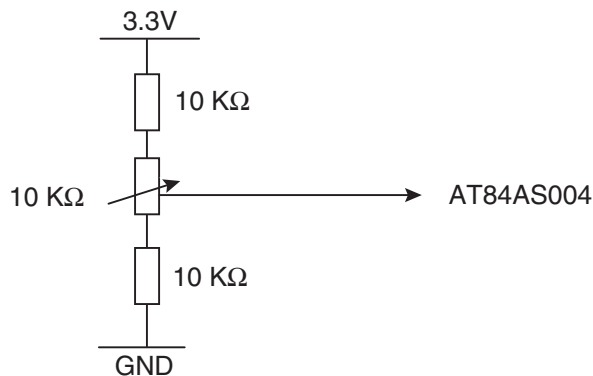

### 4.6.3 DACTRL

A standalone delay cell is available (Input = DAI/DAIN, output DAO/DAON, control = DACTRL, Enable = DAEN).

This cell allows you to delay by  $\pm 250$  ps (around 250 ps) the incoming signal DAI/DAIN via the DACTRL potentiometer (varying from  $V_{CCD}/3$  to  $(2 \times V_{CCD})/3$ ).

Figure 4-10. DACTRL Funtion

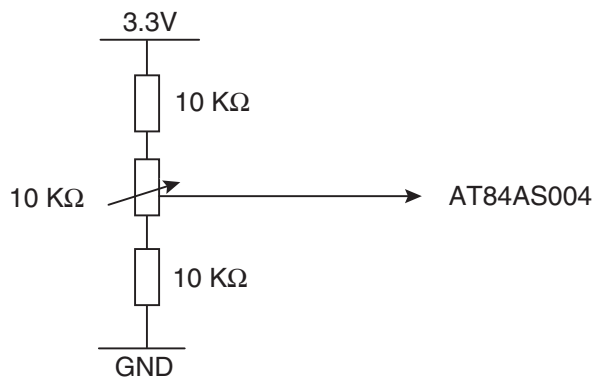

**4.6.4 RS, DRTYPE, DAEN, BIST, CLKTYPE, SLEEP, STAGG** Seven Jumpers are provided for the RS, DRTYPE, DAEN, BIST, CLKTYPE, SLEEP and STAGG functions.

Figure 4-11. DMUX Functions and Description

Function	Description	Jumper Settings
BIST	Built-In Self Test: - Active: checker-board pattern available at the device's output - Inactive: normal mode	BIST: jumper ON No BIST: jumper OUT
CLKTYPE		JUMPER OUT (ALWAYS)
DAEN	Standalone Delay Cell Enable - DAEN active: DAI/DAIN delay can be controlled via DACTRL and output in DAO/DAON - DAEN inactive: the standalone delay cell cannot be used	DAEN active: jumper ON DAEN inactive: jumper OUT
DRTYPE	Output clock mode: - DR/2 = data valid on both rising and falling edges of the DR/DRN signal - DR = data valid on each rising edge of the DR/DRN signal	DR/2: jumper ON DR: jumper OUT
RS	Ratio selection: - 1:2 - 1:4	1:2: Jumper ON 1:4: Jumper OUT
SLEEP	Sleep mode: - Active: the device is in a partial standby mode - SLEEP inactive: normal mode	SLEEP: jumper ON SLEEP: inactive: jumper OUT
STAGG	Simultaneous or staggered output mode: - STAGG active: staggered output data - STAGG inactive: simultaneous output data	STAGG: jumper ON STAGG: inactive: jumper OUT

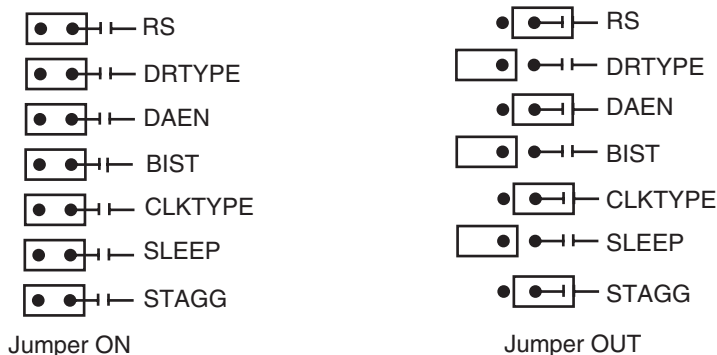
**Figure 4-12.** DMUX Functions Jumper Positions

Note: The BIST is made of a 10-bit sequence available on all 4 ports of the device (set the AT84AS004 in 1:4 mode).

The sequence is as follows:

Cycle 0:

Port A = 1010101010

Port B = 1010101010

Port C = 0101010101

Port D = 1010101010

Cycle 1:

Port B = 0101010101

Port A = 0101010101

Port C = 1010101010

Port D = 0101010101

#### 4.6.5 Additional OR bits

In simultaneous mode, the out of range signal of the ADC is demultiplexed by the DMUX and output on all ports as the (AOR/DRAN, AORN/DRA), (BOR/DRBN, BORN/DRB), (COR/DRCN, CORN/DRC) and (DOR/DRDN, DORN/DRD) signals.

These signals can be used to detect if the input of the ADC is above the full-scale.

In staggered mode, these signals correspond to the output clock for each port:

DRA, DRAN for Port A (pins A6, B6)

DRB, DRBN for Port B (pins J2, H1)

DRC, DRCN for Port C (pins W5, V5)

DRD, DRDN for Port D (pins W17, V17)

## 4.7 Diode for Die Junction Temperature Monitoring

One diode for die junction temperature measurement is available, for maximum junction temperature monitoring (hot point measurement) of the ADC.

The measurement method consists in forcing a 1 mA current into a diode mounted transistor.

The measurement setup is shown in Figure 4-7.on page 18.

**Figure 4-13.** ADC DIODE Measurement Setup

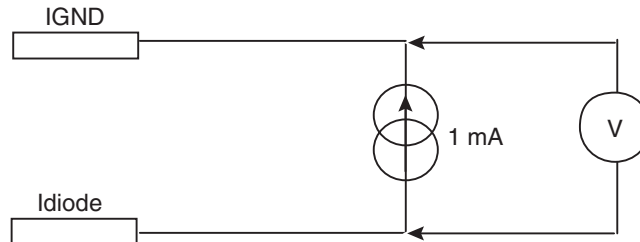

**Note:** The 1 mA current can be supplied by a multimeter set in this specific current source mode, in this case, the voltage measured between the diode pin and ground is displayed on the multimeter.

The Diode characteristic of the ADC is given in Figure 4-14

**Figure 4-14.** ADC DIODE Characteristics (I = 1 mA)

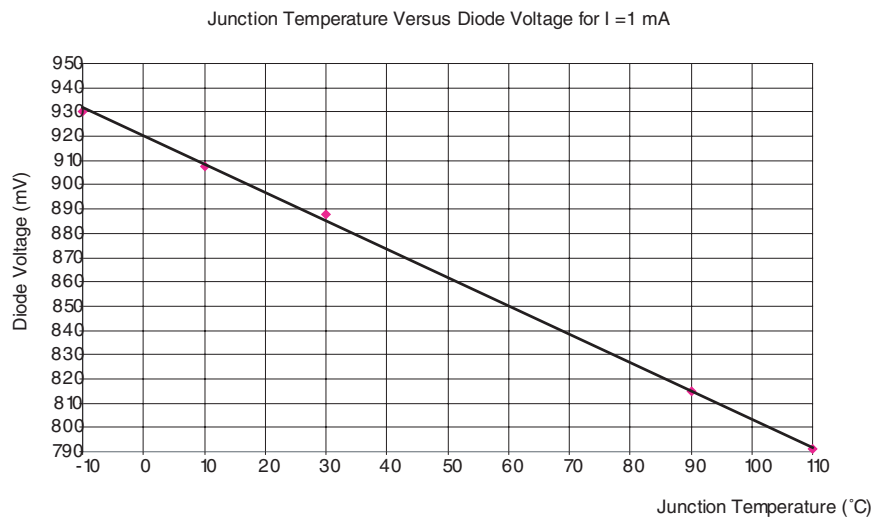

## 4.8 Test Bench Description

Figure 4-15. Test Bench Schematics

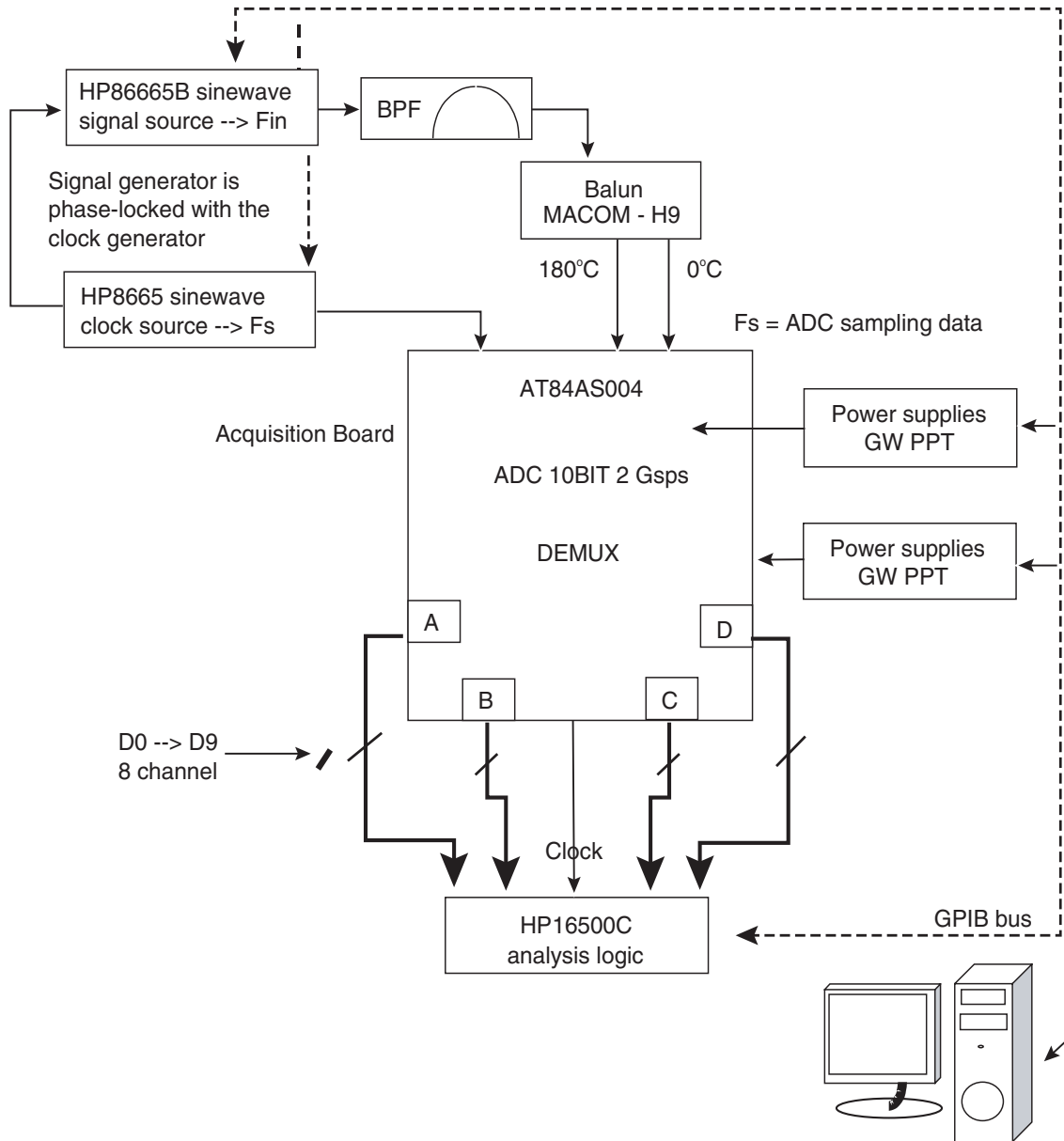





---

## Package Information

---

### 5.1 Thermal Characteristics

**Table 5-1.** Thermal Resistance

Thermal Resistance	ADC Alone	DMUX Alone
RTHj-top-of-case <sup>(1)</sup>	4.11°C/Watt	1.48°C/Watt
RTHj-bottom-of-balls <sup>(1)</sup>	6.94°C/Watt	3.89°C/Watt
RTHj-board <sup>(1)</sup>	7.98°C/Watt	4.88°C/Watt
RTHj-ambient <sup>(2)</sup>	17.13°C/Watt	13.88°C/Watt

An external heat sink must be placed on top of package.

It is advised to use an external heat sink with intrinsic thermal resistance better than 4°C/Watt when using air at room temperature 20~25°C.

Use an external heat sink with intrinsic thermal resistance better than 3°C/Watt when using air at 60°C.

- Notes:
1. No air, pure conduction, no radiation
  2. Jedec condition, still and horizontal air (board thick = 1.6 mm)



---

**Ordering Information**
**Table 6-1.**

Part Number	Package	Temperature Range	Screening	Comments
AT84XAS004TP	EBGA 317	Ambient	Prototype	Prototype version Please contact your local sales office
AT84AS004CTP	EBGA 317	Commercial C $0^{\circ}\text{C} < T_C, T_J < 90^{\circ}\text{C}$	Standard	
AT84AS004VTP	EBGA 317	Industrial "V" grade $-20^{\circ}\text{C} < T_C; T_J < 110^{\circ}\text{C}$	Standard	
AT84XAS004TPY	EBGA 317 RoHS	Ambient	Prototype	Please contact your local sales office
AT84AS004CTPY	EBGA 317 RoHS	/Commercial "C" grade $0^{\circ}\text{C} < T_C; T_J < 90^{\circ}\text{C}$	Standard	
AT84AS004VTPY	EBGA 317 RoHS	Industrial "V" grade $-20^{\circ}\text{C} < T_C; T_J < 110^{\circ}\text{C}$	Standard	
AT84AS004TP-EB	EBGA 317	Ambient	Prototype	Evaluation kit



#### 7.1 AT84AS004-EB Electrical Schematics

Figure 7-1. Power Supplies Decoupling

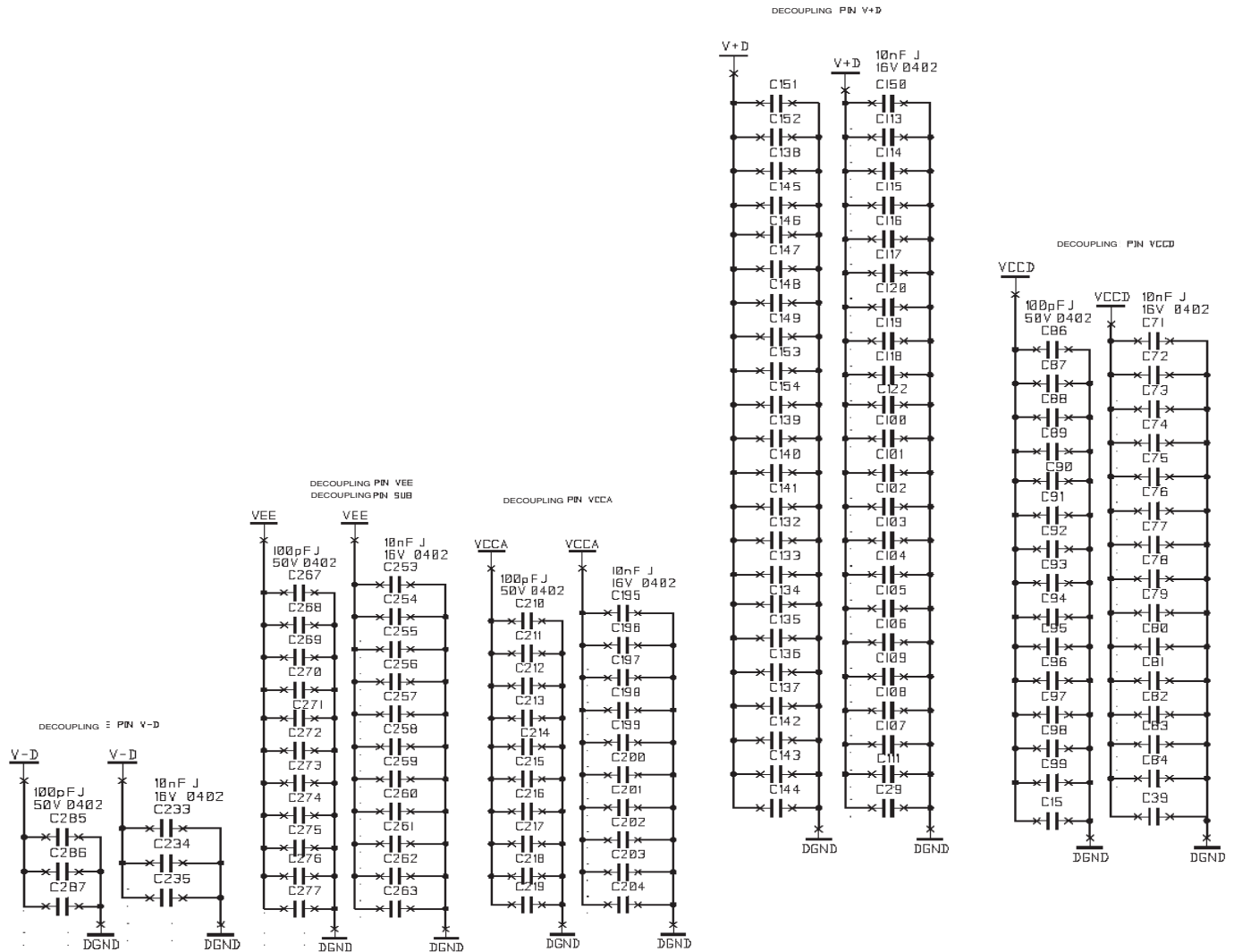

Figure 7-2. Power Supplies Connection

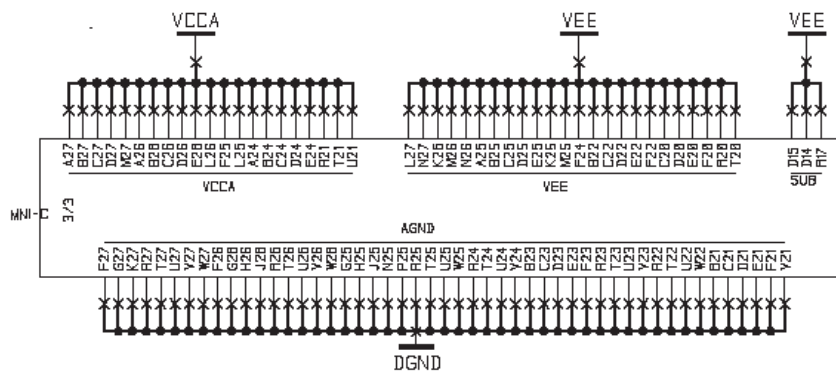
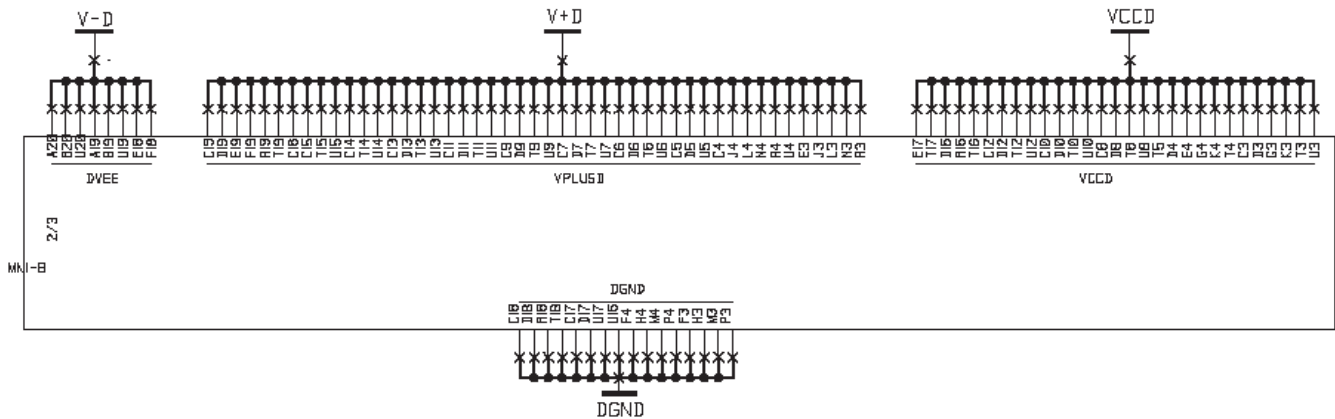

Figure 7-3. Power Supplies bypassing

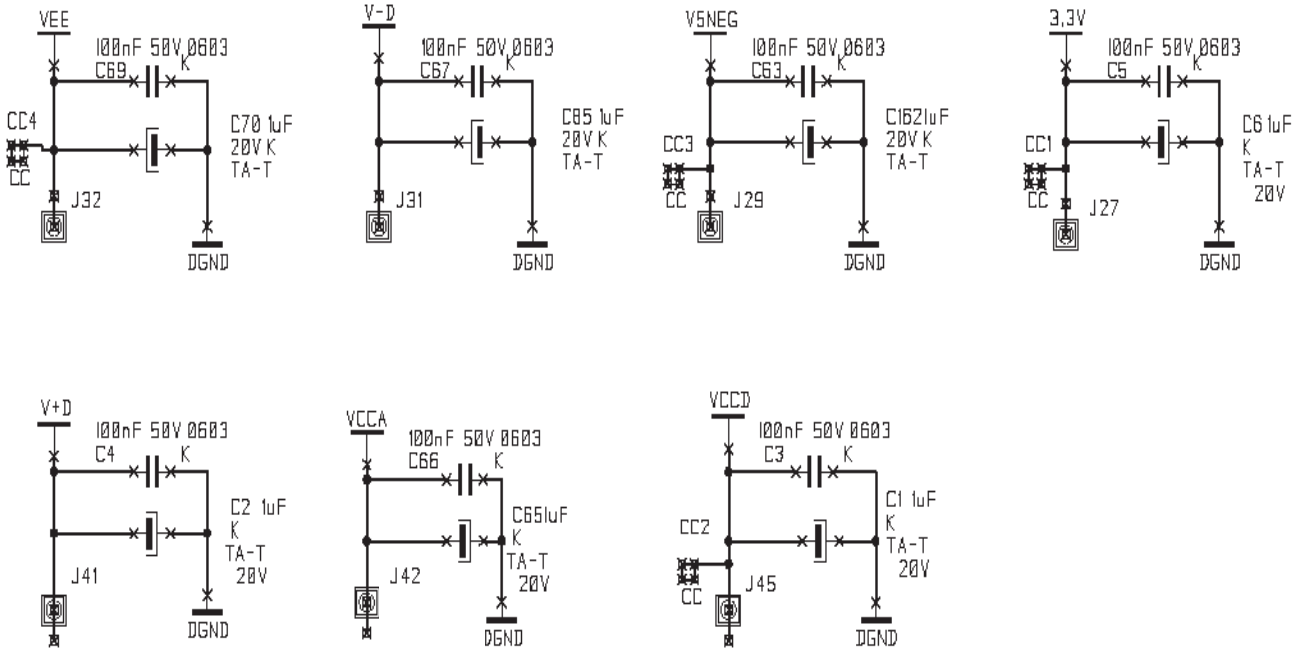
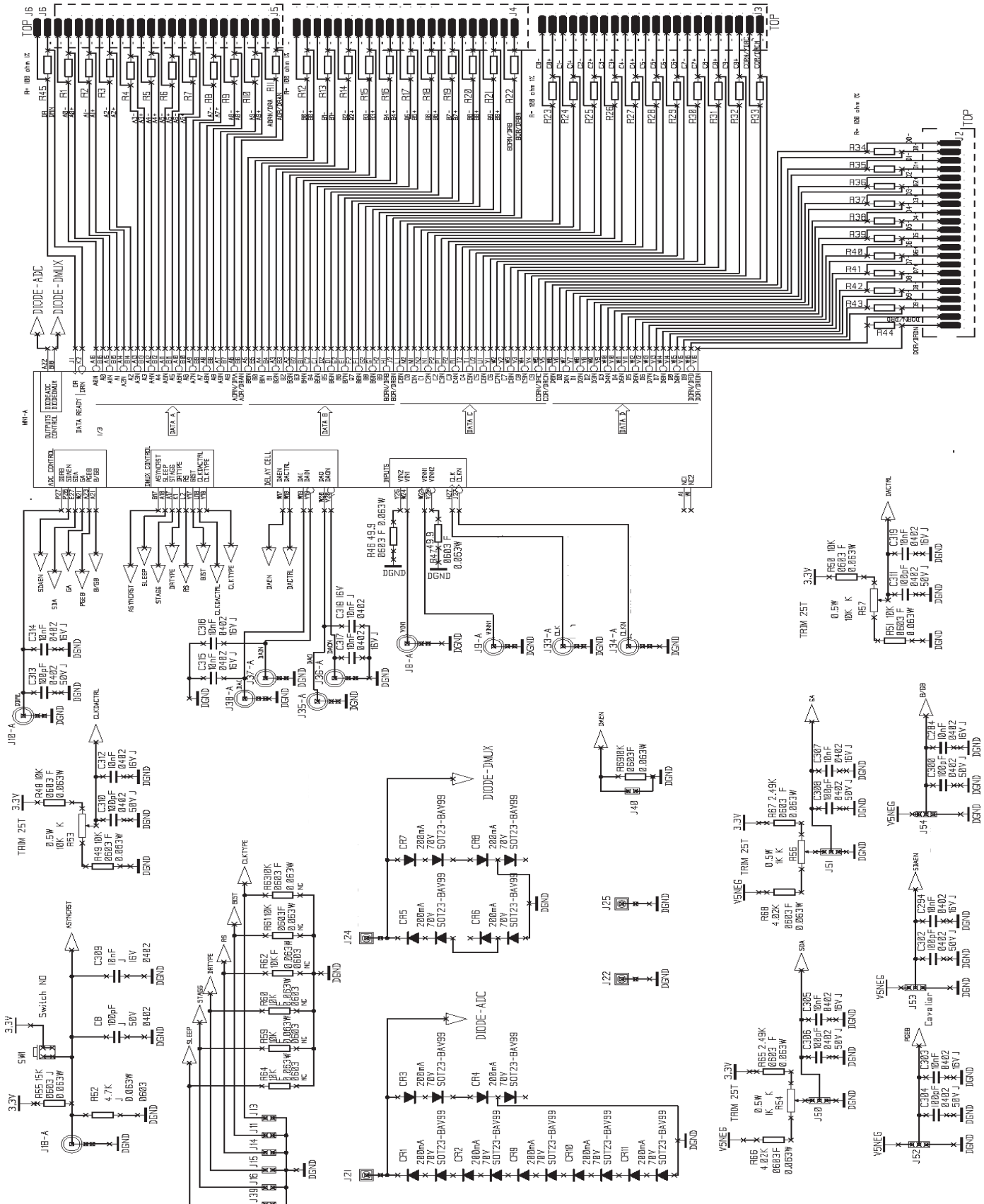

Figure 7-4. AT84AS004-EB Electrical Schematic



## 7.2 AT84AS004-EB Board Layers

Figure 7-5. Top Layer

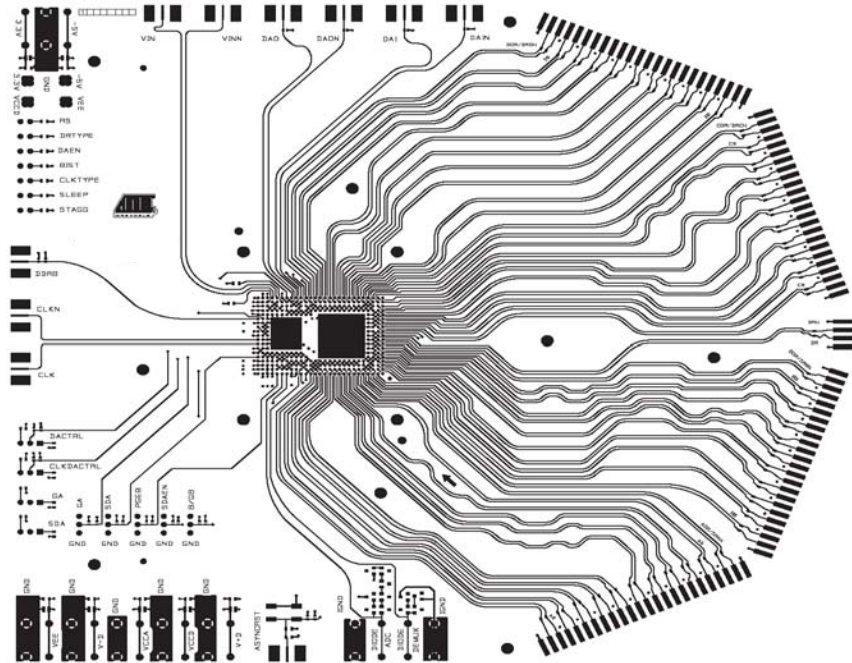

Figure 7-6. Bottom Layer

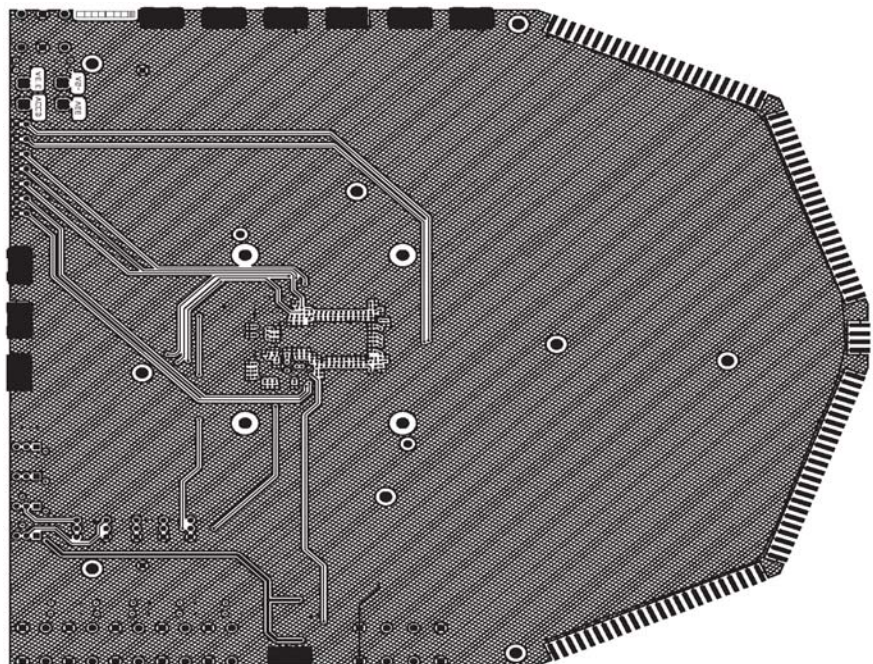



Figure 7-7. Equipped Board (Top)

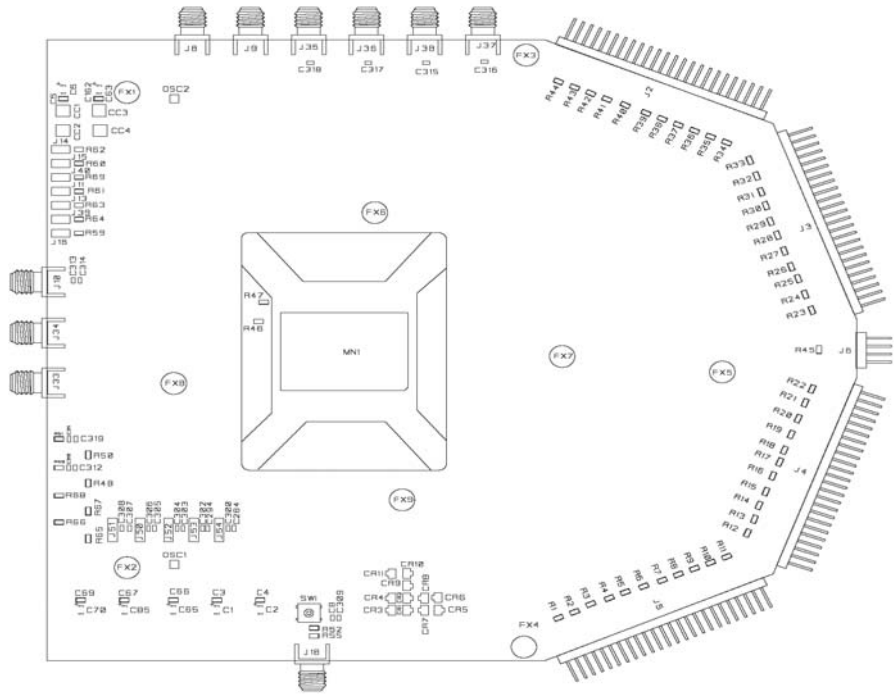
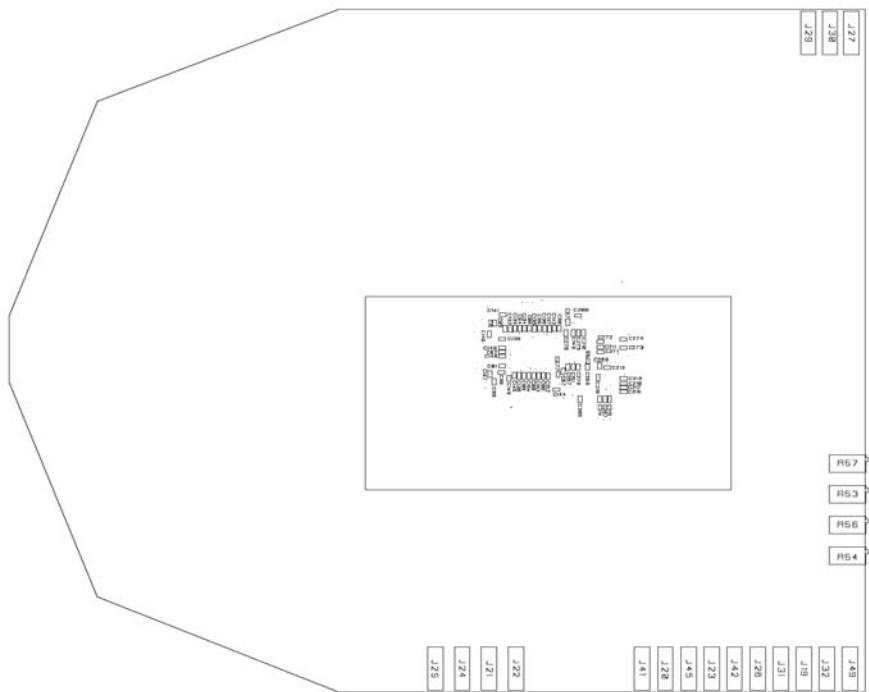

Figure 7-8. Equipped Board (Bottom)







## How to reach us

Home page: [www.e2v.com](http://www.e2v.com)

### Sales Office:

#### **Northern Europe**

##### **e2v ltd.**

106 Waterhouse Lane  
Chelmsford  
Essex CM1 2QU  
England  
Tel: +44 (0)1245 493493  
Fax: +44 (0)1245 492492  
E-Mail: [enquiries@e2v.com](mailto:enquiries@e2v.com)

#### **Southern Europe**

##### **e2v sas**

16 Burospace  
F-91572 Bièvres  
Cedex  
France  
Tel: +33 (0) 16019 5500  
Fax: +33 (0) 16019 5529  
E-Mail: [enquiries-fr@e2v.com](mailto:enquiries-fr@e2v.com)

#### **Germany and Austria**

##### **e2v gmbh**

Industriestraße 29  
82194 Gröbenzell  
Germany  
Tel: +49 (0) 8142 41057-0  
Fax: +49 (0) 8142 284547  
E-Mail: [enquiries-de@e2v.com](mailto:enquiries-de@e2v.com)

#### **Americas**

##### **e2v inc.**

4 Westchester Plaza  
Elmsford  
NY 10523-1482  
USA  
Tel: +1 (914) 592 6050 or  
1-800-342-5338,  
Fax: +1 (914) 592-5148  
E-Mail: [enquiries-na@e2v.com](mailto:enquiries-na@e2v.com)

#### **Asia Pacific**

##### **e2v**

Bank of China Tower  
30th floor office 7  
1 Garden Rd Central  
Hong Kong  
Tel: +852 2251 8227/8/9  
Fax: +852 2251 8238  
E-Mail: [enquiries-hk@e2v.com](mailto:enquiries-hk@e2v.com)

#### **Product Contact:**

##### **e2v**

Avenue de Rochepleine  
BP 123 - 38521 Saint-Egrève Cedex  
France  
Tel: +33 (0)4 76 58 30 00

##### **Hotline:**

[hotline-bdc@e2v.com](mailto:hotline-bdc@e2v.com)

Whilst e2v has taken care to ensure the accuracy of the information contained herein it accepts no responsibility for the consequences of any use thereof and also reserves the right to change the specification of goods without notice. e2v accepts no liability beyond that set out in its standard conditions of sale in respect of infringement of third party patents arising from the use of tubes or other devices in accordance with information contained herein.